

HP58 / TEFC INSTALLATION GUIDE

Introduction

This Guide provides instructions for installing Joral's HP58 non-contact magnetic encoder onto a standard TEFC (Totally Enclosed, Fan-Cooled) motor. The process involves two main stages: securely mounting the magnet to the motor shaft and then mounting the encoder to the motor's fan shroud, ensuring proper alignment.

Disclaimer

These instructions are generalized guidelines. The end-user is responsible for ensuring the mounting methods are suitable and robust for their their specific application, environment, motor size, and shaft configuration. Always consult the official HP58 datasheet for specific electrical wiring and operational parameters.

Safety First!

Remember to disconnect and lock out all power to the motor before beginning installation.

Suggested Tools and Materials

- Joral HP58 Encoder and matching Magnet Puck
- Screwdrivers and/or Allen Wrenches
- Tape measurer or calipers
- Mounting hardware (screws, washers, bolts)
- Chosen magnet mounting supplier (see part 1, pg. 2)

Fan Diagram

- Measure the depth from the back of the fan guard to the top of the shaft
- Including the magnet thickness, the minimum gap should be .060" and maximum .50"

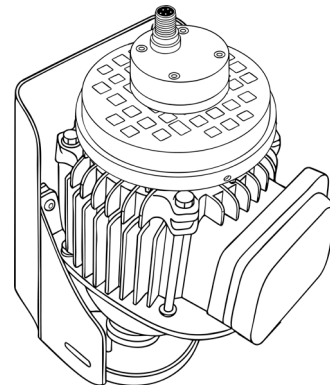

Ring Magnet Dimensions

	R1008D45H	R1010D
Thickness	.118" (3mm)	.118" (3mm)
Inside Diameter	.315" (8mm)	.472" (12mm)
Outside Diameter	.472" (12mm)	.750" (19.05mm)

Part 1: Magnet Installation

The primary goal of the step is to securely fasten the magnet centered on the end of the motor shaft. The motor's fan shroud will likely need to be removed to access the shaft. The shaft end must be clean and free of grease or debris. Please note: The HP58 allows 0.10" center misalignment, so if it is not perfectly aligned it will still work.

Critical Task: Centering the Magnet

An off-center magnet more than 0.10 of an inch will cause inaccurate readings. The center of the magnet puck must align with the absolute center of the shaft's rotation.

These methods can be used in combination to achieve proper spacing and improve redundancy.

Method A: Holder with Set Screw. This method uses a machined or printed holder that is secured with a screw.

1. Use or create a holder that fits the magnet puck.
2. Slide the holder over the motor shaft.
3. Carefully center the holder by measuring its position relative to the shaft.
4. Tighten the set screws simultaneously against the shaft to lock it in place. Using a set screw with nylon tip can prevent damage to the shaft.

Notes: If needed, Jorall can provide a holder if given the correct dimensions of the shaft and fan shroud.

Method B: High-Strength Adhesive

1. Thoroughly clean the face of the motor shaft and the back of the magnet with a decreasing agent.
2. Apply a suitable industrial adhesive (e.g., 3M Epoxy Adhesive DP420)
3. Carefully place the magnet onto the center of the shaft.
4. Apply gentle pressure and ensure the magnet does not shift while the adhesive cures. Allow for full cure time as per the adhesive manufacturer's instructions.

Method C: Heat Shrink Tubing (For smaller shafts) This method is best when the magnet is nearly the same diameter as the shaft.

1. Place the magnet at the center of the shaft.
2. Place a piece of heavy-wall, industrial-grade heat shrink tubing over the magnet and shaft.
3. Carefully apply heat with a heat gun, starting from the middle and working outwards, to shrink the tubing tightly. The pressure from the tubing will hold the magnet in place.
4. Cut the tubing flush with the magnet to avoid contact with other essential components.

Part 2: Encoder Installation

With the magnet installed, the encoder body needs to be mounted to the motor's fanshroud. The goal is to position the encoder so it is centered over the magnet and maintains less than a 0.5" air gap. The center of a steel/ferrous fan shroud should be drilled just oversized of the outside dimension of the magnet to allow for the best magnetic connection.

Critical Task: Alignment and Air Gap

The recommended air gap between the face of the magnet and the face of the HP58 encoder is typically < 0.5". Failure to maintain this gap can result in poor signal quality.

1. Position the Encoder: Place the HP58 encoder onto the center of the fan shroud, directly over the installed magnet.
2. Visual Alignment: Look through the bore of the encoder. You should see the "X" on the magnet sticker. Adjust the position of the encoder until the center of its bore lines up perfectly with the intersection of the "X".
3. Marking Mounting Holes: Once aligned, use a marker or center punch to mark the locations for the mounting holes on the fan shroud through the slots on the encoder's mounting flange.
4. Drill Mounting Holes: Remove the encoder and carefully drill holes in the fan shroud at the marked locations.
5. Drilling Shroud: The hole should be ~.010" larger than the outside dimension of the magnet to allow for the best magnetic coupling.
6. Secure the Encoder: Place the encoder back onto the shroud. Insert at least two #4-40 x 1.5" screws through the newly drilled holes in the fan shroud holes and then through the encoder. On the top of the encoder, place a washer and a nut on each screw.
7. Final Tightening: Center the encoder and securely tighten the mounting screws. Tighten them in an alternating pattern to ensure even pressure.

Part 3: Final Checks and Wiring

- Verification: Verification: If possible, manually rotate the motor shaft by hand. Ensure there is no contact or rubbing between the magnet, encoder, and mounting hardware.
- Wiring: Connect the encoder's cable as specified in the HP58 datasheet for your specific model (e.g., Quadrature, CANOpen, J1939, Analog). Ensure wiring is protected from physical damage and is routed away from the high-voltage motor leads.
- Power Up & Test: Re-connect power to the motor and test the system to confirm you are receiving a stable and accurate position signal from the encoder.
- Further Troubleshooting: For further troubleshooting, please do not hesitate to reach out to Joral LLC through phone or email.

