



US 20090072816A1

(19) **United States**

(12) **Patent Application Publication**  
**Schrubbe et al.**

(10) **Pub. No.: US 2009/0072816 A1**

(43) **Pub. Date: Mar. 19, 2009**

(54) **ROTARY MAGNETIC ENCODER ASSEMBLY,  
CHIP AND METHOD**

**Publication Classification**

(76) Inventors: **Carl D. Schrubbe**, Waukesha, WI  
(US); **David P. Engsborg**, New  
Berlin, WI (US)

(51) **Int. Cl.**  
**G01B 7/30** (2006.01)  
**G01R 33/07** (2006.01)  
(52) **U.S. Cl.** ..... **324/207.2; 324/207.25**

Correspondence Address:  
**BOYLE FREDRICKSON S.C.**  
**840 North Plankinton Avenue**  
**MILWAUKEE, WI 53203 (US)**

(57) **ABSTRACT**

A rotary magnetic encoder assembly that has a freewheeling rotatable exciter magnet onboard that excites a magnetic field sensor region of an encoder chip when magnetic interaction between the exciter magnet and rotating encoder shaft causes the exciter magnet to rotate. In one embodiment, a drive magnet carried by the shaft magnetically couples with the exciter magnet because the medium therebetween has low magnetic permeability enabling rotation substantially in unison with the shaft. The exciter magnet is disposed in an onboard retainer pocket that accurately locates the magnet relative to the sensor region of the encoder chip. In one preferred embodiment, the exciter magnet retainer pocket is disposed onboard the encoder chip, such as by being formed as part of the package body of the chip that can be integrally formed or as part of a module that is mountable on the chip.

(21) Appl. No.: **12/205,902**

(22) Filed: **Sep. 7, 2008**

**Related U.S. Application Data**

(60) Provisional application No. 60/970,865, filed on Sep. 7, 2007, provisional application No. 61/049,382, filed on Apr. 30, 2008.

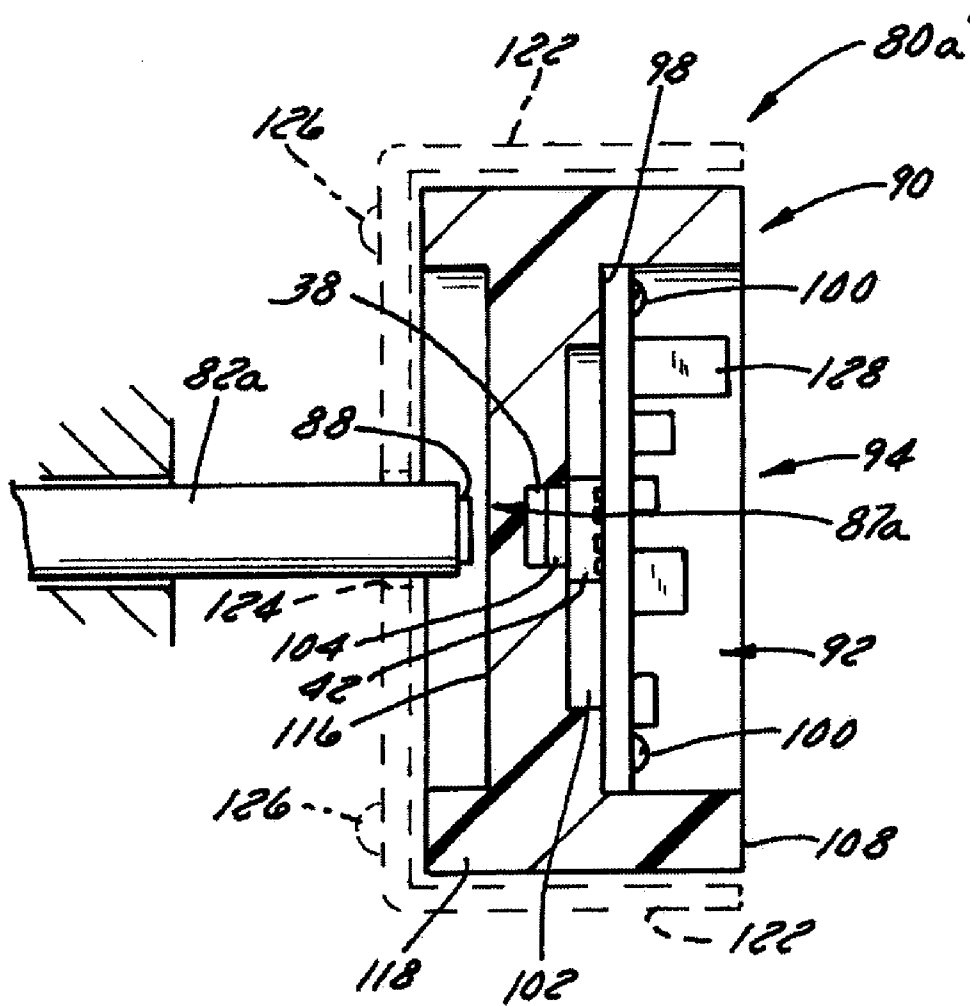

FIG. 1  
PRIOR ART

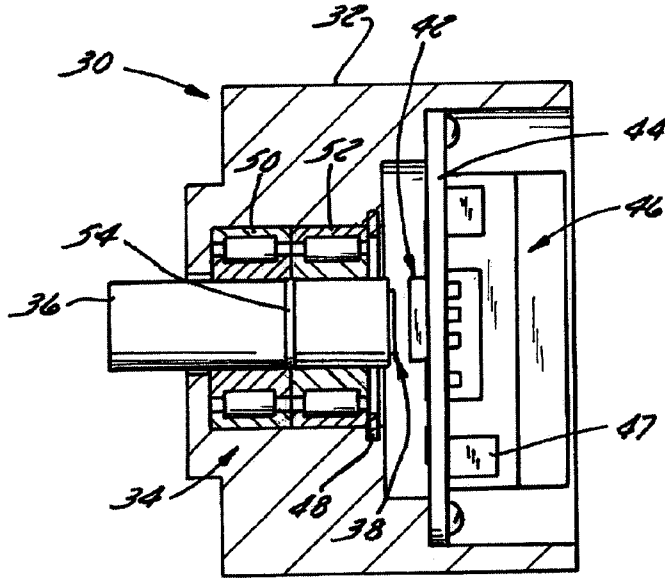

FIG. 2  
PRIOR ART

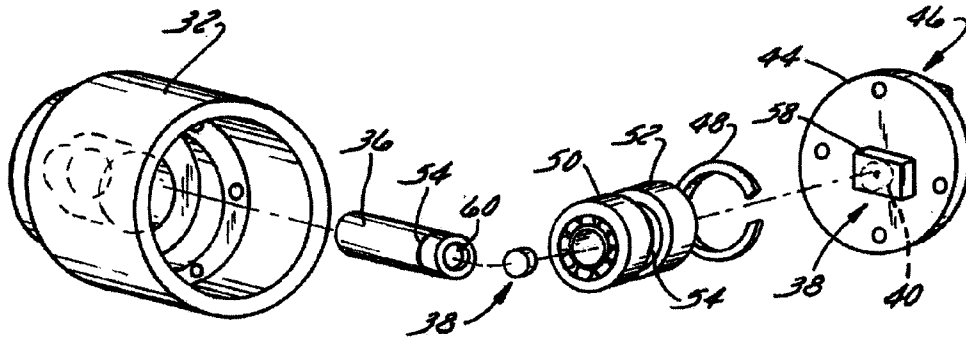
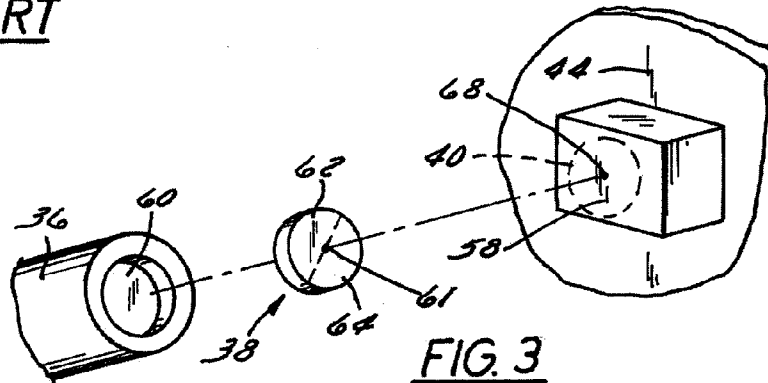
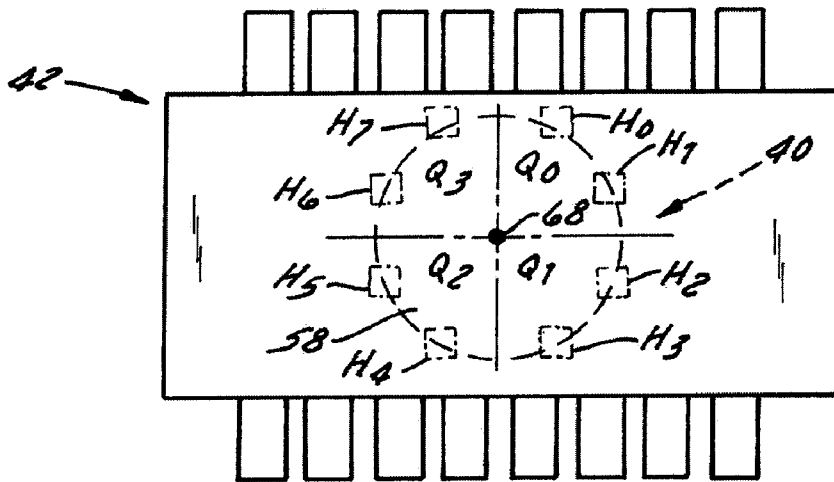
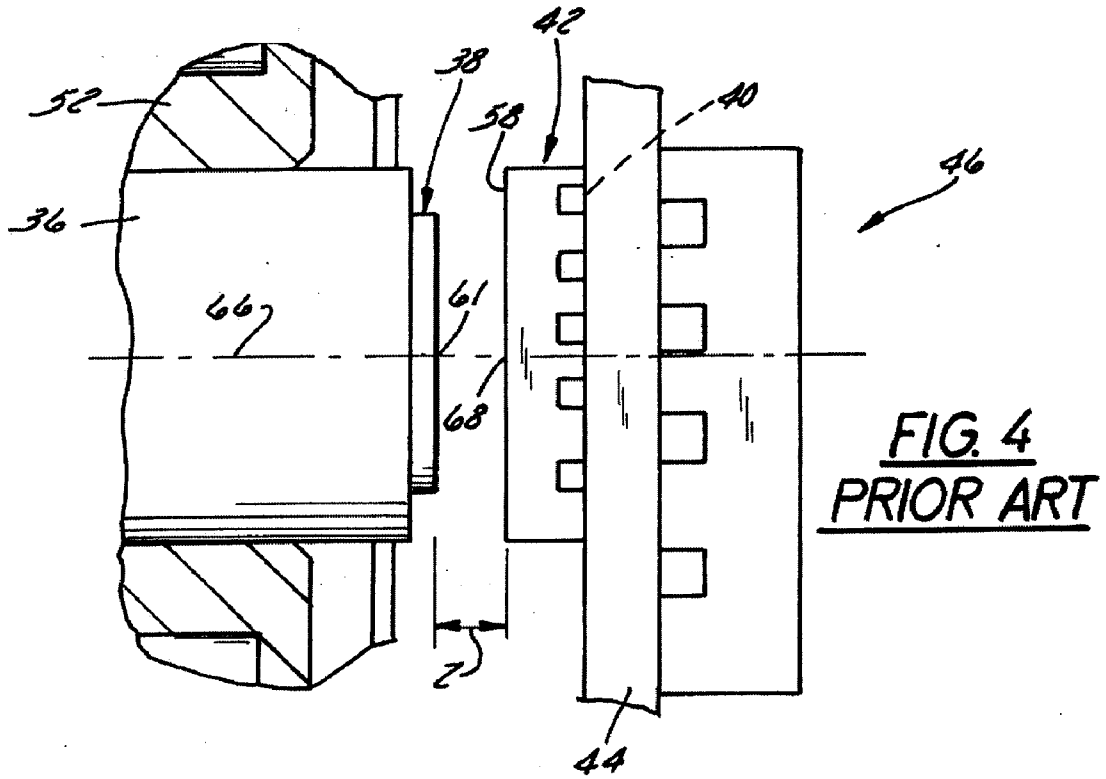

FIG. 3  
PRIOR ART





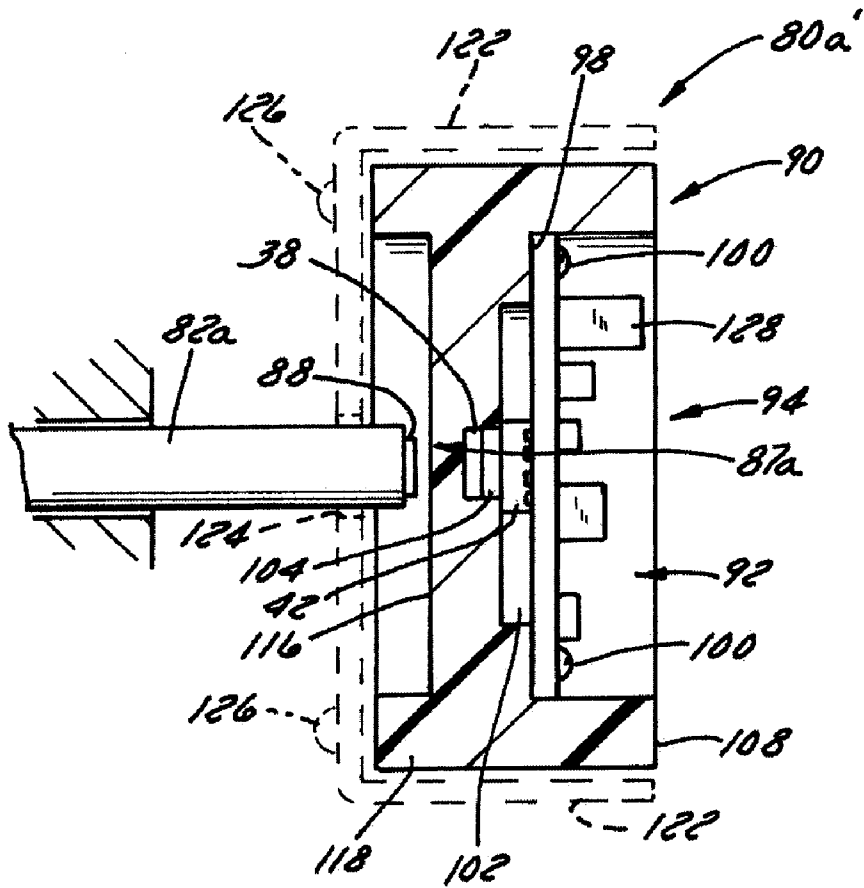

FIG. 6

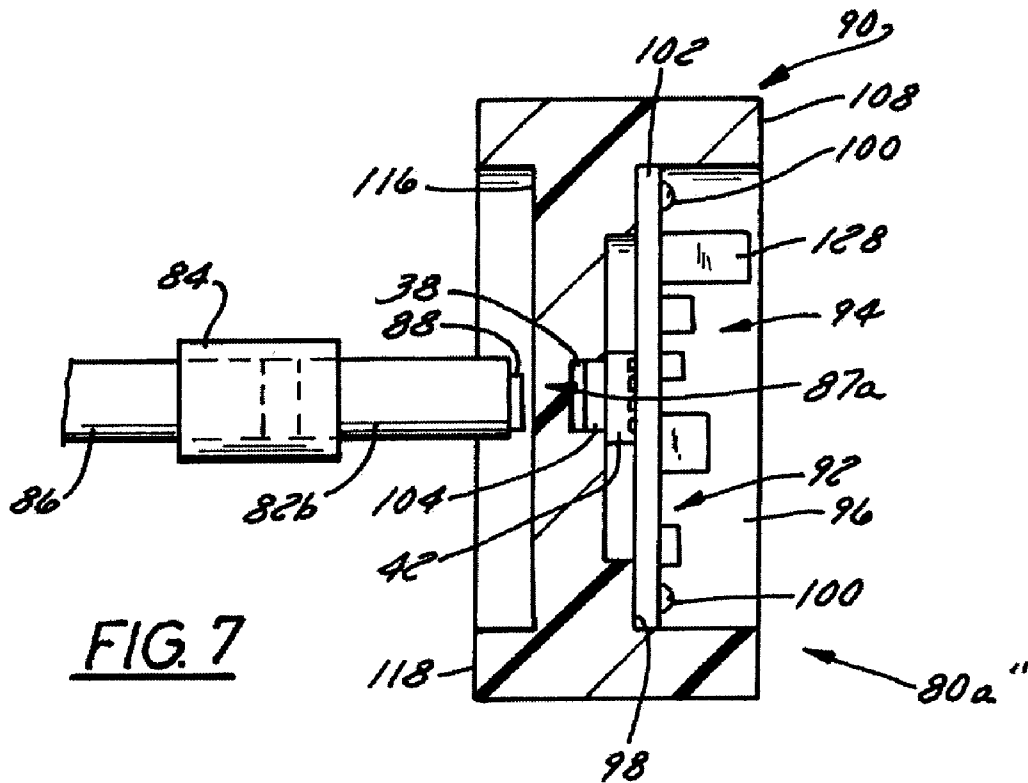
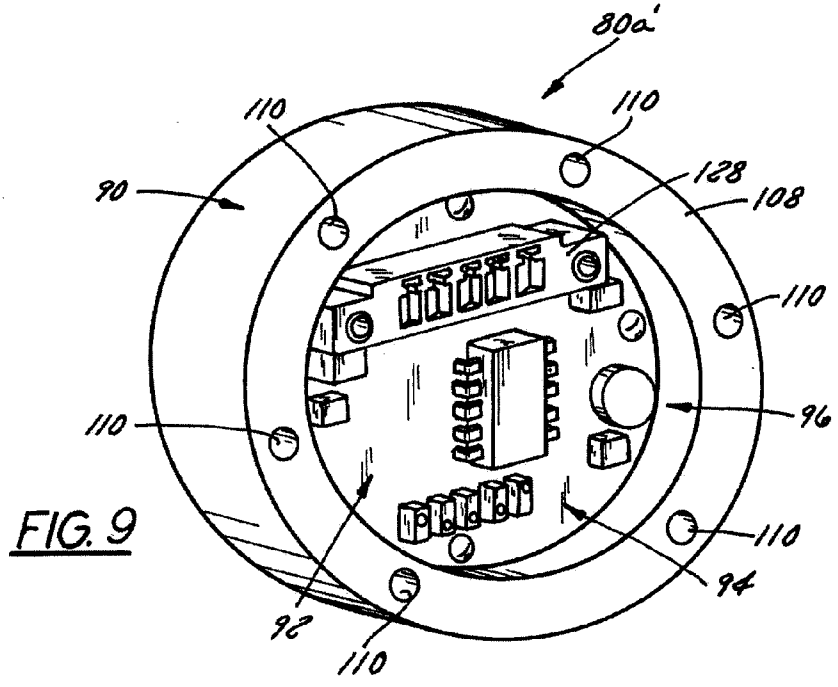
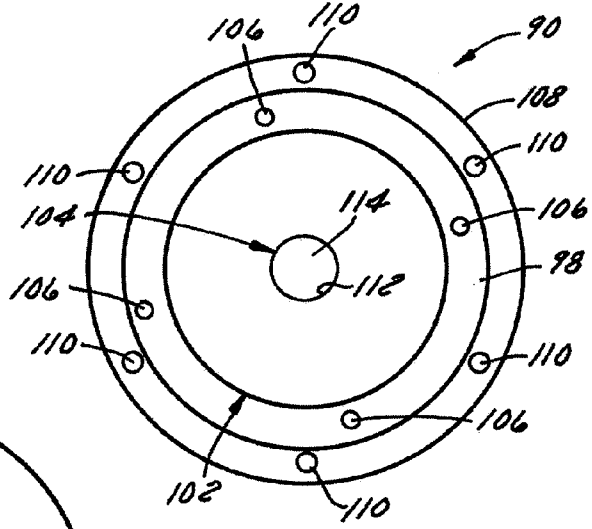

FIG. 7

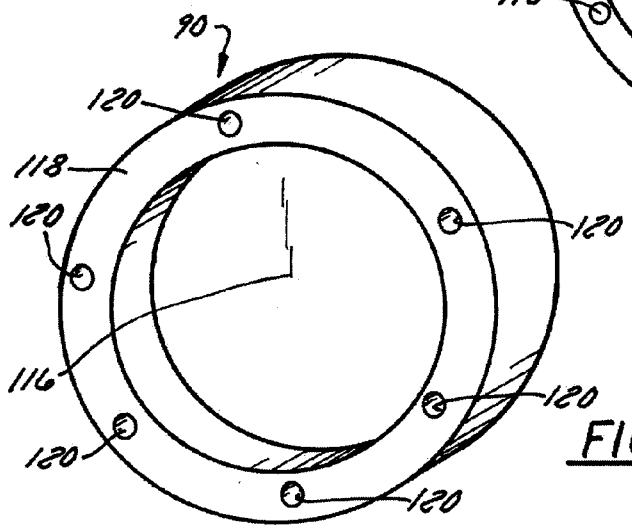



**FIG. 9**



**FIG. 10**



**FIG. 11**

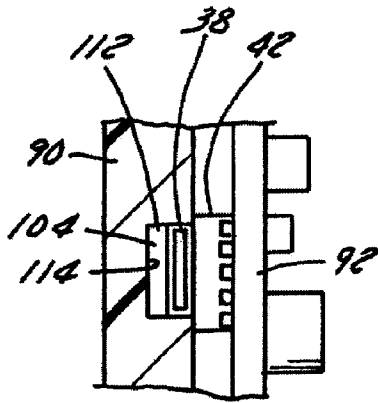

FIG. 12

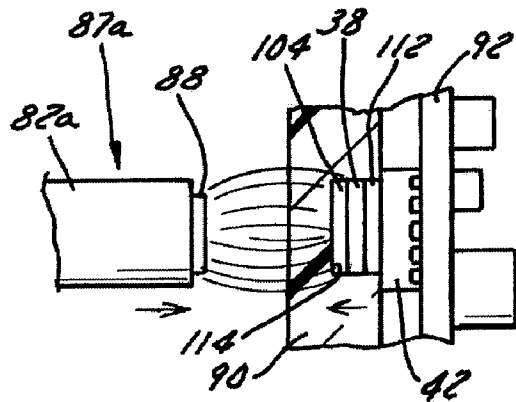

FIG. 13

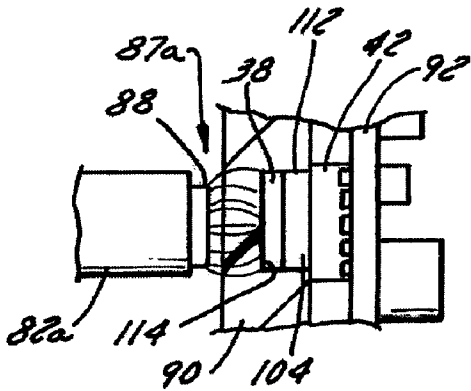

FIG. 14

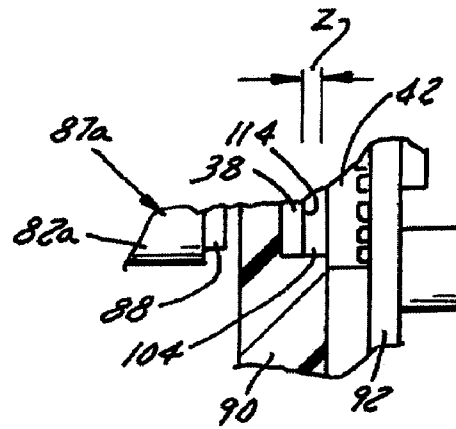

FIG. 15

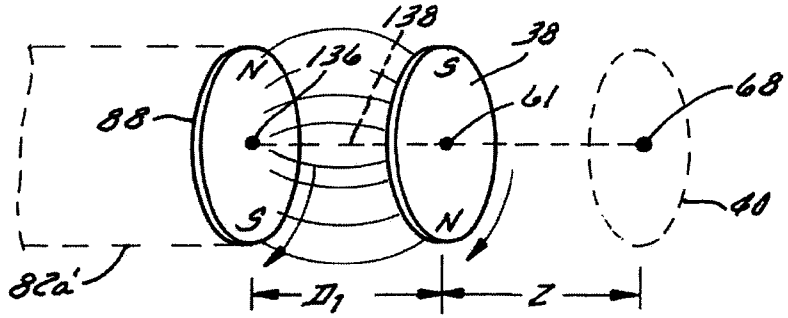

FIG. 16

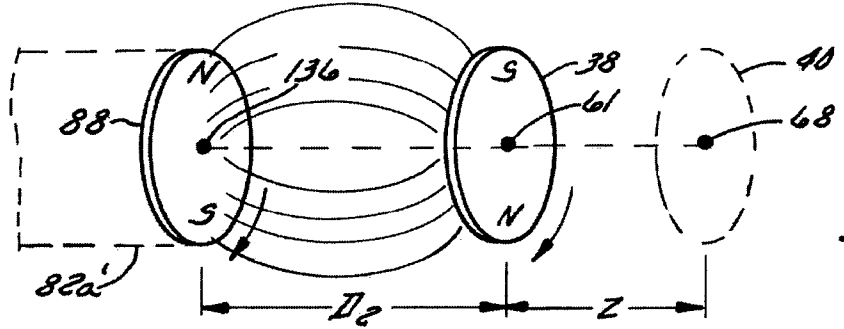

FIG. 17

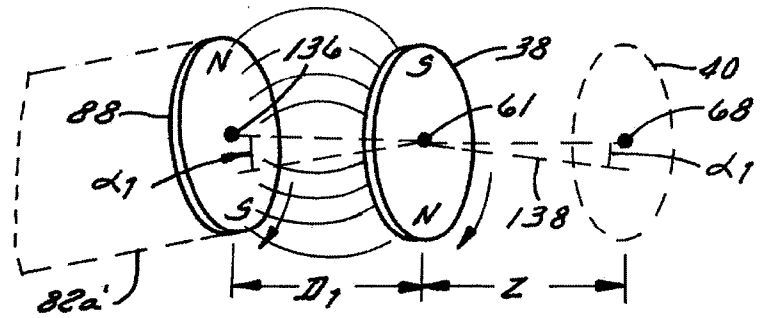

FIG. 18

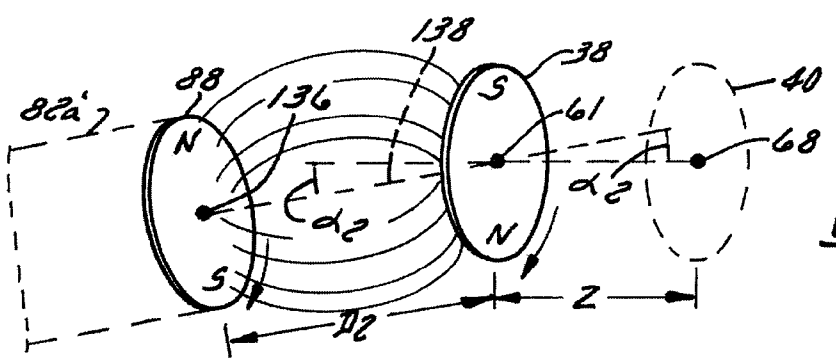

FIG. 19

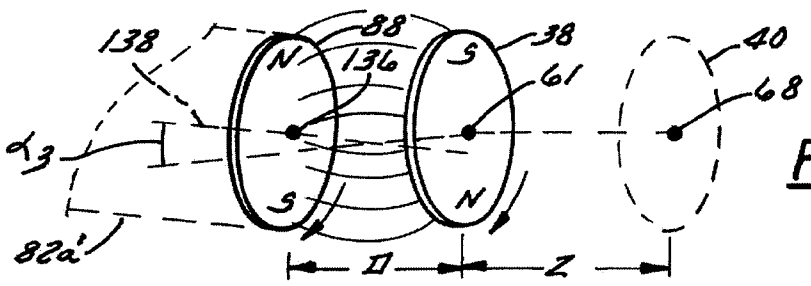
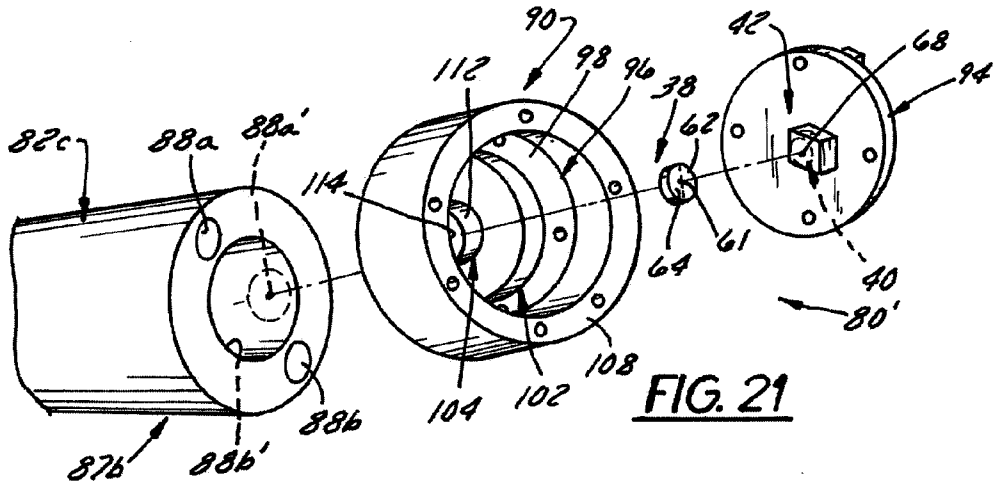
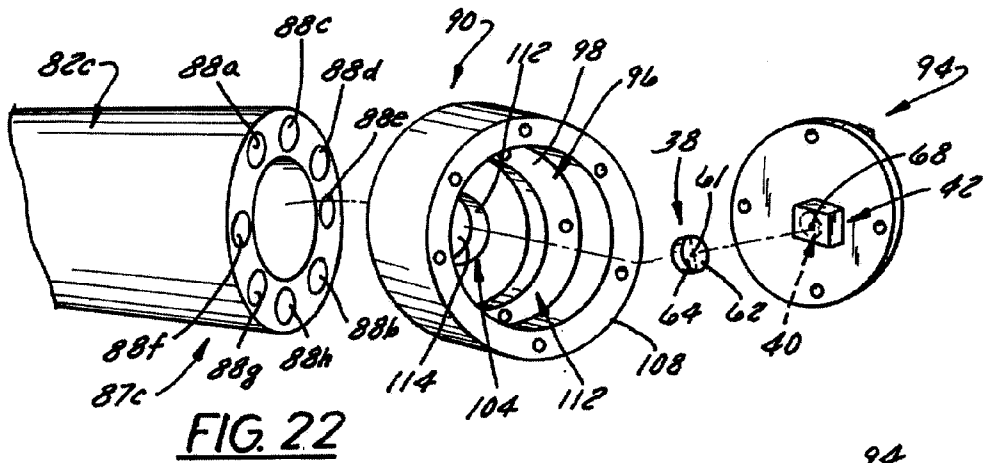

FIG. 20



**FIG. 21**



**FIG. 22**

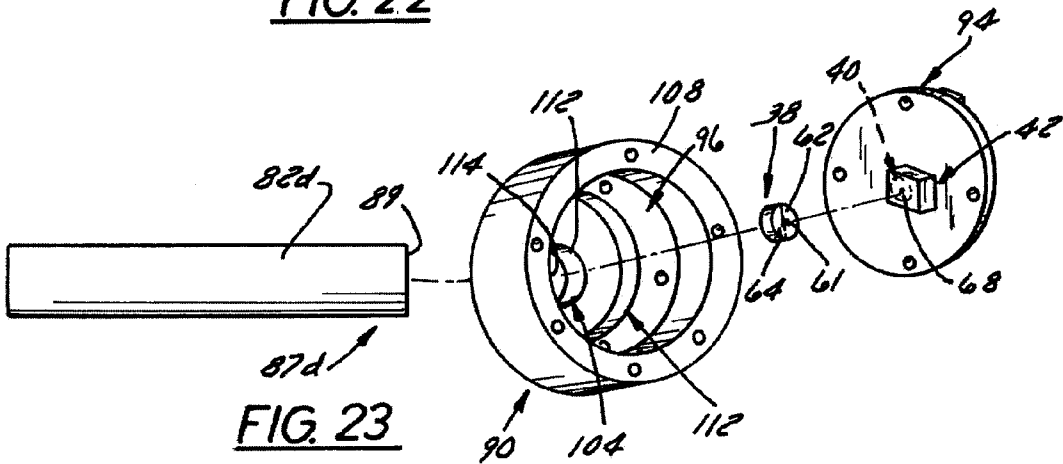

**FIG. 23**

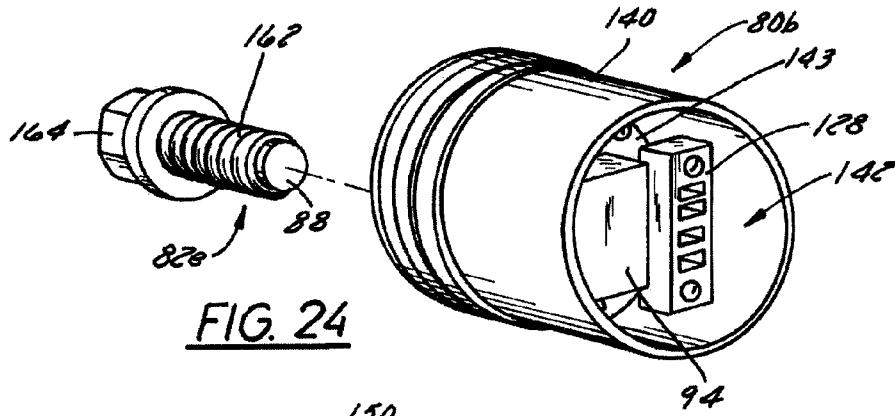

FIG. 24

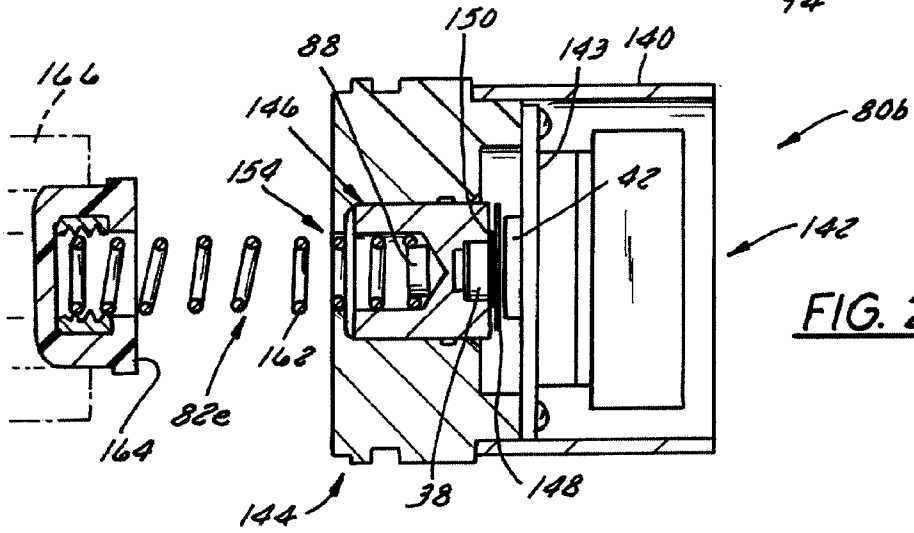

FIG. 25

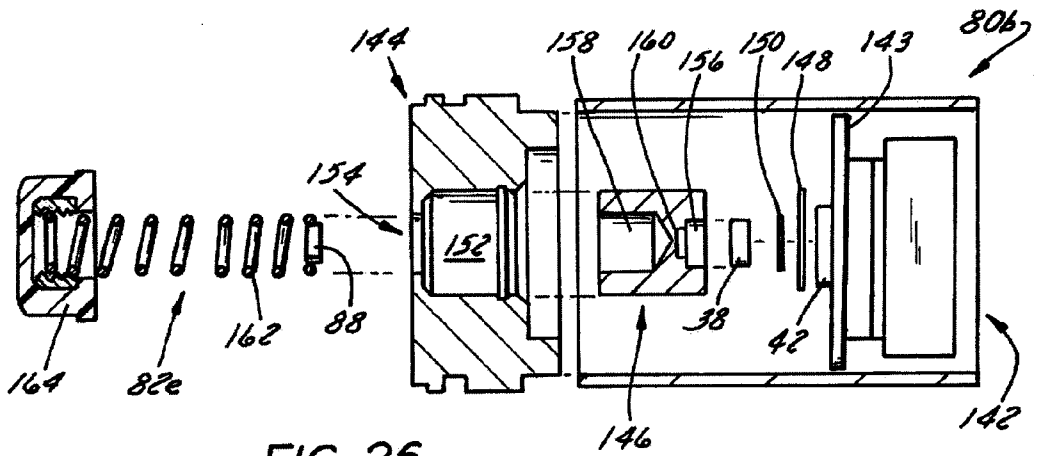

FIG. 26

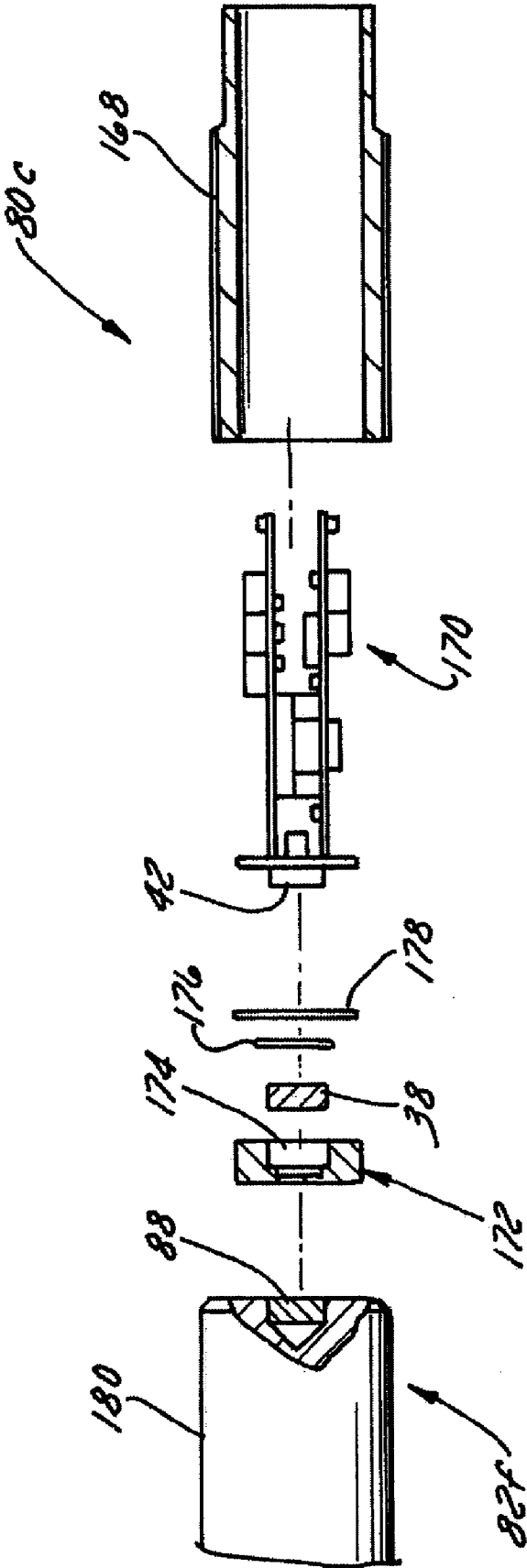
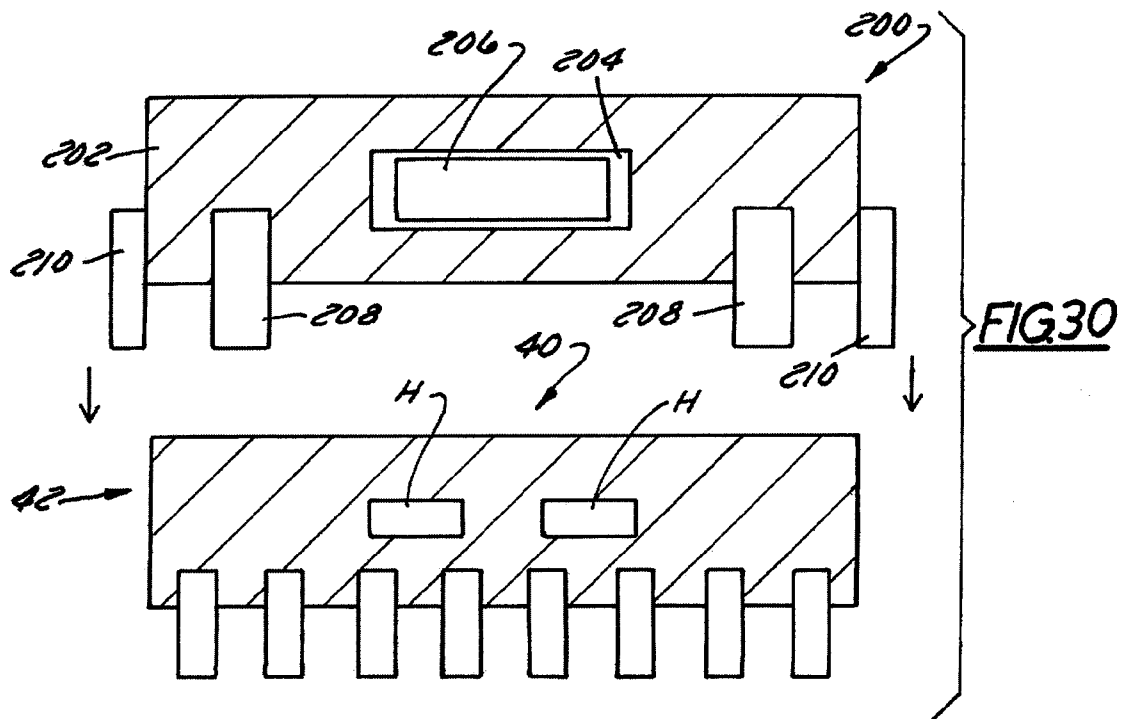
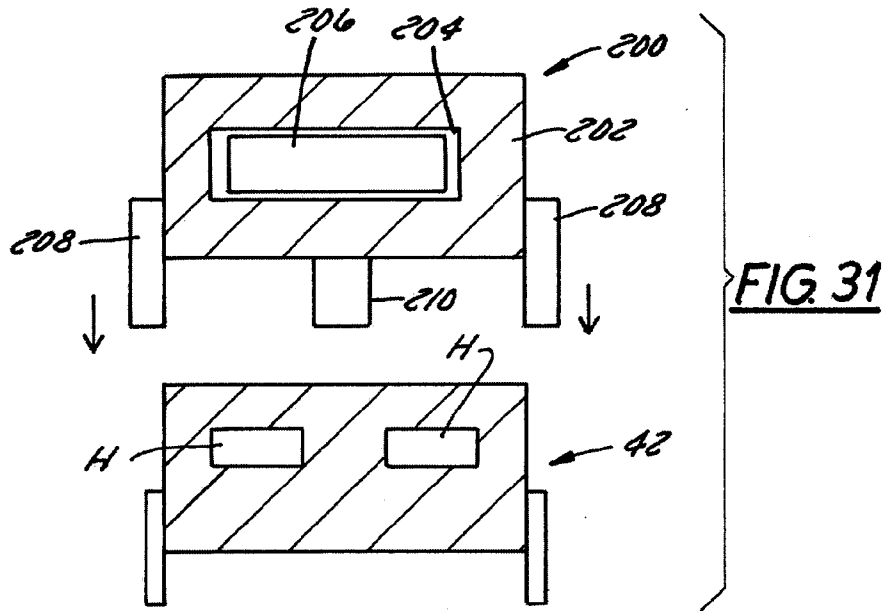

FIG. 27





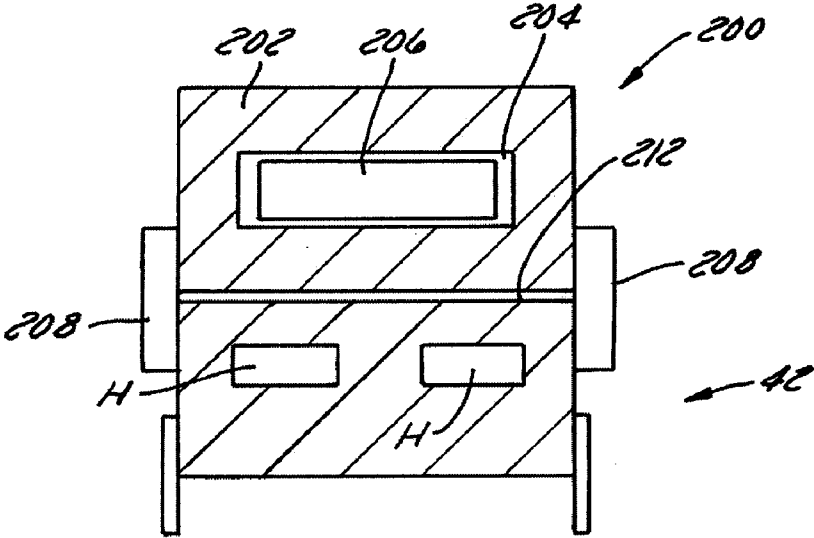

FIG. 33

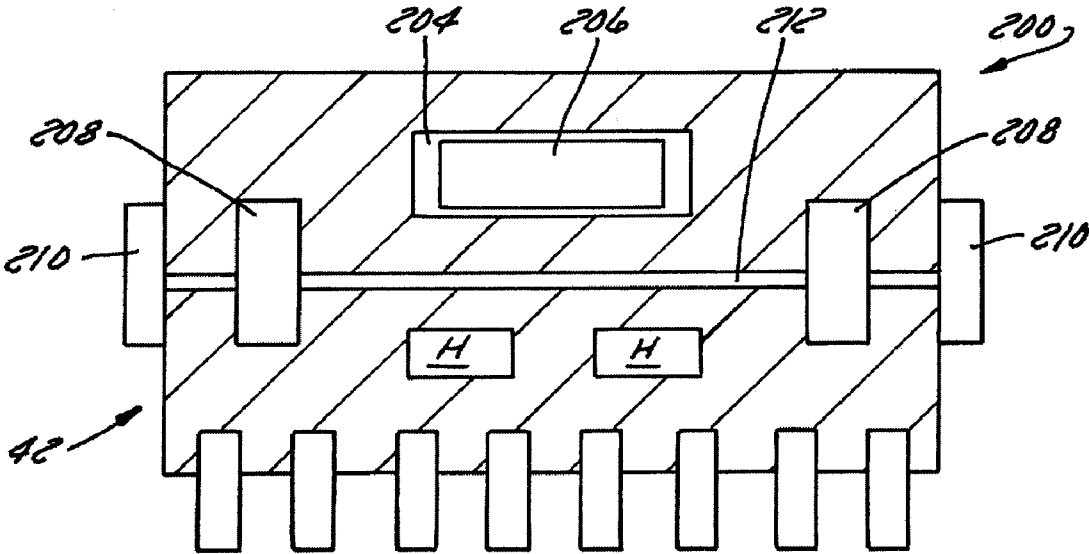

FIG. 32

**ROTARY MAGNETIC ENCODER ASSEMBLY,  
CHIP AND METHOD**

**CROSS-REFERENCE**

**[0001]** This application claims the benefit under 35 U.S.C. § 119(e) of U.S. Provisional Application Ser. No. 60/970,865, filed Sep. 7, 2007, and U.S. Provisional Application Ser. No. 61/049,382, filed Apr. 30, 2008, the entirety of both of which are expressly incorporated by reference herein.

**FIELD**

**[0002]** The present invention relates to an improved rotary magnetic encoder assembly, magnetic encoder integrated circuit therefor as well as a related method of use or operation.

**BACKGROUND**

**[0003]** Rotary encoders of optical or magnetic construction are used to measure or sense rotation, typically of a shaft or the like, by providing rotational-related data from which information, such as absolute or relative rotary position can be determined. Rotary encoders are very versatile and used in applications that frequently require controlling the motion of a rotating object, such as a shaft or the like. Other applications include: monitoring motor feedback, cut-to-length applications, filling applications, backstop applications, robotics, etc.

**[0004]** Optical rotary encoders typically use a circular disk that has sections coded, such as by being blacked out or otherwise marked, that turns with the object whose rotary movement is being measured. A sensor reads light reflected from the disk in determining whether there has been a change in rotary position of the disk.

**[0005]** While optical rotary encoders have enjoyed a great deal of commercial success, they nonetheless suffer from numerous drawbacks. They are undesirably complicated, sensitive to dust, oil and dirt, mechanically fragile, typically cannot be used in relatively high temperature environments, and are susceptible to shock and vibration.

**[0006]** Magnetic rotary encoders have a construction that overcomes most, if not nearly all, of these disadvantages. However, in the past, magnetic rotary encoders require relatively precise axial and radial positioning of an encoder shaft-mounted magnet used to excite Hall Effect sensors that define a sensor region of a magnetic rotary encoder chip. Since the Hall sensors inside the encoder chip require a uniform magnetic field distribution, failure to maintain such precise exciter magnet location produces increased signal noise, causes positional error, or both, which obviously is highly undesirable.

**[0007]** What is therefore needed is a rotary magnetic encoder that does not suffer the drawbacks of rotary optical encoders but is more tolerant to encoder shaft misalignment than conventional rotary magnetic encoders.

**SUMMARY**

**[0008]** The present invention is directed to at least one of a rotary magnetic encoder assembly, rotary magnetic encoder chip therefor as well as a method of use and operation thereof. A rotary magnetic encoder chip having a magnetic field sensor arranged defined by at least a plurality of Hall sensors arranged in an array that defines a sensor region experiences a magnetic field of a rotatable exciter magnet retained in a magnet retainer that locates the exciter magnet relative to the

Hall sensors to help ensure consistent and accurate operation even where there is significant encoder shaft misalignment, mislocation or both. The encoder shaft effects rotation of the rotatable exciter magnet without contacting the exciter magnet. The retainer is an exciter-magnet holding pocket that is disposed onboard the rotary magnetic encoder assembly and which can be disposed on or onboard the rotary magnetic encoder chip.

**[0009]** A rotary magnetic encoder assembly constructed in accordance with the present invention includes an encoder body and/or housing that carries either an encoder chip having a rotatable exciter magnet retainer and rotatable exciter magnet or which includes such a retainer carried by the encoder body or housing in a manner that maintains accurate location of the rotatable exciter magnet relative to the sensor region of the encoder chip. In one preferred embodiment, the retainer is a rotatable exciter magnet-holding pocket formed in a portion of the encoder body. In another preferred embodiment, the retainer is a rotatable exciter magnet-holding pocket formed in an insert disposed in engagement with the encoder body and/or encoder housing. Such an insert can also be carried by a carriage that is carried by an encoder housing or otherwise disposed within the housing.

**[0010]** The encoder shaft is a rotary shaft equipped with a drive coupler that causes the exciter magnet to rotate when the shaft rotates without there being physical contact therebetween. Such a drive coupler can include one or more drive magnets disposed at or adjacent the free end of the encoder shaft that magnetically couple with the exciter magnet to cause the exciter magnet to rotate when the encoder shaft rotates. Such a drive coupler can be made of a magnetic material, e.g., ferromagnetic material, located in close enough proximity to the exciter magnet that encoder shaft rotation causes or effects exciter magnet rotation even though there is no physical contact therebetween. Where the encoder shaft is of ferromagnetic construction at or adjacent its free end and carries a drive magnet, the drive coupler is configured so that the drive magnet preferably is magnetically isolated by a non-magnetic material such as bronze, non-magnetic stainless steel or the like.

**[0011]** Such a rotary magnetic encoder assembly has any medium disposed between the exciter magnet and an adjacent free end of the encoder shaft being of relatively low magnetic permeability so that magnetic lines of flux flow substantially without interruption between the exciter magnet and encoder shaft end thereby linking the flux lines enabling rotation of the exciter magnet to be effected by encoder shaft rotation. Where the medium is a solid medium, such as where it includes a portion of the exciter magnet retainer in which a magnet-holding pocket is disposed, it has a relatively low permeability on the order of a non-ferromagnetic material which can be as low as the permeability of a vacuum as this facilitates effecting rotation of the exciter magnet by the encoder shaft by helping to maximize flux linkage. To facilitate freewheeling rotation of the exciter magnet so that it rotates substantially in unison with the encoder shaft relatively shortly after shaft rotation begins, the material from which the magnet holding pocket is formed has a relatively low coefficient of friction.

**[0012]** Any medium disposed between the rotative exciter magnet and sensor arrangement/sensor region can also have relatively low magnetic permeability such that the sensor arrangement/sensor region of the encoder chip experiences a substantially uniform magnetic field from the exciter magnet

due to it being accurately axially, radially and angularly located relative thereto by being retained in the pocket of the retainer. The exciter magnet preferably is a permanent magnet of bipolar construction having a center disposed in line with a center of the sensor arrangement/sensor region of the encoder chip due to it being located by being in the pocket of the retainer.

[0013] In one preferred encoder chip embodiment, the package body of the chip includes the exciter magnet retainer with its pocket in which the rotatable exciter magnet is disposed being integrally formed. In another preferred embodiment, a layer is disposed on the package body that includes the pocket with the magnet disposed therein. In still another embodiment, the exciter magnet is disposed in a pocket of a module that is attachable to the package body of an encoder chip.

[0014] In a method in accordance with the present invention, rotation of the encoder shaft effects rotation of the exciter magnet, whose moving magnetic field interacts with the Hall sensors of the sensor region of the fixed encoder chip causing the chip to output a signal or data indicative of rotary position, rotary angle, rotational speed, or the like. In one preferred embodiment where the encoder shaft includes a drive coupler that includes a drive magnet, rotation of the exciter magnet is caused by magnetic coupling between the drive magnet and exciter magnet. As a result, the encoder shaft no longer must be precisely located using one or more encoder shaft bearings attached to the encoder body or encoder housing, resulting in a rotary magnetic encoder assembly that is bearing-less so as to be of more economical construction and which is advantageously more tolerant of encoder shaft misalignment and mislocation.

#### DRAWING DESCRIPTION

[0015] Preferred exemplary embodiments of the invention are illustrated in the accompanying photographs, in which like reference numerals represent like parts throughout, and in which:

[0016] FIG. 1 is a cross sectional view of a prior art rotary magnetic encoder assembly illustrating a bearing arrangement used to precisely position an exciter magnet relative to a rotary magnetic encoder integrated circuit chip to ensure it outputs a good signal;

[0017] FIG. 2 is an exploded view of the prior art rotary magnetic encoder assembly of FIG. 1;

[0018] FIG. 3 is an enlarged fragmentary exploded view of an encoder shaft, exciter magnet and rotary magnetic encoder integrated circuit chip of the prior art rotary magnetic encoder assembly of FIG. 1;

[0019] FIG. 4 is an enlarged fragmentary cross sectional view of the encoder shaft and exciter magnet precisely located relative to the rotary magnetic encoder integrated circuit chip of the prior art rotary magnetic encoder assembly of FIG. 1;

[0020] FIG. 5 is a top plan view of the rotary magnetic encoder integrated circuit chip showing its sensor region comprised of an array of Hall Effect sensors or switches;

[0021] FIG. 6 is one variant of a first preferred embodiment of an encoder shaft angular misalignment and mislocation tolerant rotary magnetic encoder assembly constructed in accordance with the present invention;

[0022] FIG. 7 is another variant of the first preferred rotary magnetic encoder assembly embodiment where the encoder shaft is connected by a coupling to a drive or driven shaft;

[0023] FIG. 8 is an exploded view of the first preferred rotary magnetic encoder assembly embodiment;

[0024] FIG. 9 is an enlarged perspective view of the first preferred rotary magnetic encoder assembly embodiment;

[0025] FIG. 10 is a front elevation view of a "puck" shaped encoder body of the first preferred rotary magnetic encoder assembly embodiment;

[0026] FIG. 11 is a rear elevation view of the "puck" shaped encoder body;

[0027] FIG. 12 is an enlarged fragmentary cross sectional view of an exciter magnet held captive in a pocket of the encoder body in an uncoupled state;

[0028] FIG. 13 is an enlarged fragmentary cross sectional view of the exciter magnet held captive in a pocket of the encoder body being drawn into coupling with a drive magnet carried by an encoder shaft of the first preferred rotary magnetic encoder assembly embodiment;

[0029] FIG. 14 is an enlarged fragmentary cross sectional view of the exciter magnet magnetically coupled with the encoder shaft drive magnet;

[0030] FIG. 15 is an enlarged fragmentary cross sectional view of the exciter magnet magnetically coupled with the encoder shaft drive magnet cutaway to show how magnetic coupling also locates the exciter magnet relative to the rotary magnetic encoder integrated circuit chip;

[0031] FIG. 16 illustrates a first magnetic coupling case with exemplary flux lines shown where the drive magnet, exciter magnet and sensor region of the rotary magnetic encoder integrated circuit chip are aligned with the drive magnet magnetically coupled with the exciter magnet;

[0032] FIG. 17 illustrates a second magnetic coupling case with exemplary flux lines shown where the spacing between the drive magnet and exciter magnet is increased showing spacing tolerance of the first preferred rotary magnetic encoder assembly embodiment;

[0033] FIG. 18 illustrates a third magnetic coupling case with exemplary flux lines shown where there is angular misalignment between the drive magnet and exciter magnet while magnetic coupling therebetween is maintained;

[0034] FIG. 19 illustrates a fourth magnetic coupling case with exemplary flux lines shown where there is angular misalignment and increased spacing between the drive magnet and exciter magnet while magnetic coupling is maintained;

[0035] FIG. 20 illustrates a fifth magnetic coupling case with exemplary flux lines shown where the drive magnet is radially offset and angularly misaligned relative to the exciter magnet while maintaining magnetic coupling therebetween;

[0036] FIG. 21 illustrates one preferred drive coupling arrangement where a pair of opposite pole magnets are attached to the encoder shaft and couple with the exciter magnet;

[0037] FIG. 22 illustrates another preferred drive coupling arrangement where several drive magnets are used to couple with the exciter magnet;

[0038] FIG. 23 illustrates still another preferred drive coupling arrangement where the encoder shaft either includes a magnet with a single pole facing toward the exciter magnet or is made of a magnetically attractive material that is located close enough to the exciter magnet so as to effectively couple with the exciter magnet;

[0039] FIG. 24 is a perspective view of a second preferred embodiment of a rotary magnetic encoder assembly constructed in accordance with the present invention where the

encoder shaft includes a resilient biasing element that carries a drive coupling that is a drive magnet;

[0040] FIG. 25 is a cross-sectional view of the second preferred rotary magnetic encoder assembly embodiment of FIG. 24;

[0041] FIG. 26 is an exploded cross-sectional view of the second preferred rotary magnetic encoder assembly embodiment of FIG. 24;

[0042] FIG. 27 is an exploded view of a third preferred rotary magnetic encoder assembly embodiment;

[0043] FIG. 28 is a cross-sectional view of a rotary magnetic encoder chip equipped with an integral exciter magnet in its package body;

[0044] FIG. 29 is a preferred embodiment of a rotary magnetic encoder assembly embodiment with the rotary magnetic encoder chip of FIG. 28 shown enlarged for clarity;

[0045] FIG. 30 is an exploded side elevation view of an exciter magnet module and conventional rotary magnetic encoder chip;

[0046] FIG. 31 is an exploded end elevation view of the exciter magnet module and conventional rotary magnetic encoder chip of FIG. 30;

[0047] FIG. 32 is a side elevation view of the module shown in FIGS. 30 and 31 attached to the conventional rotary magnetic encoder chip; and

[0048] FIG. 22 is an end elevation view of the module shown in FIGS. 30 and 31 attached to the conventional rotary magnetic encoder chip.

[0049] Before explaining embodiments of the invention in detail, it is to be understood that the invention is not limited in its application to the details of construction and the arrangement of the components set forth in the following description and illustrated in the drawings. The invention is capable of other embodiments or being practiced or carried out in various ways. Also, it is to be understood that the phraseology and terminology employed herein is for the purpose of description and should not be regarded as limiting.

## DETAILED DESCRIPTION

### Introduction

[0050] An example of a prior art rotary magnetic encoder 30 is shown in FIGS. 1-5. With specific reference to FIGS. 1-3, the encoder 30 has a substantially rigid housing 32 in which is fixed a bearing arrangement 34 that cooperates with a rotary encoder shaft 36 having a sensor exciter magnet 38 fixed in its free end that overlies a magnetic field sensor region 40 of a magnetic rotary encoder integrated circuit chip 42 attached to a circuit board 44 that is fixed to the housing 32. The circuit board 44 has onboard electronics 46 used to process data from the encoder chip 42 and output data or a signal that is representative of or which relates to rotary movement of the shaft 36 via a connector 47. Shaft 36 can be directly connected to that which is being measured or can be connected by a coupling (not shown) or the like to another shaft or other component that is being rotated or otherwise displaced in a manner lending itself to rotary encoder measurement.

[0051] The bearing arrangement 34 is held in place against the encoder housing 32 by a locking ring 48 and includes at least one shaft bearing 50, 52 to help ensure the shaft 36 runs axially true for preventing the magnet 38 from wobbling during shaft rotation. The bearing arrangement 34 also includes means to axially lock the shaft 36, such as by use of

a ring 54 or the like that seats in a groove 56 (FIG. 2) formed in the shaft 36, so that the gap, Z (FIG. 4), between the end of the exciter magnet 38 and the outer surface 58 of the encoder chip 42 is maintained within a desired tolerance.

[0052] The exciter magnet 38 is a bi-polar disk-shaped permanent magnet that is fixed in a pocket 60 in the free end of the encoder shaft 36. The magnet 38 is bisected with one magnet half defining a North pole 62 and the other magnet half defining a South pole 64. The magnet 38 is relatively small, typically having a diameter of about 6 millimeters and a height or thickness of no more than about 2.5 millimeters, but is powerful as it is typically a rare earth Alnico (AlNiCo), samarium cobalt (SmCo5), or neodymium (NdFeB) magnet.

[0053] The location of the exciter magnet 38 must be precisely located relative to the sensor region 40 of the encoder chip 42. The magnet 38 must be centered such that its axial center 61 is substantially coaxial with an axis of rotation 66 of the shaft and a center 68 of the sensor region 40 within an accepted minimal tolerance. This is to ensure that an array of Hall sensors, H<sub>0</sub>-H<sub>7</sub>, arranged generally as depicted in FIG. 5 in four quadrants, Q<sub>0</sub>-Q<sub>3</sub>, of the sensor region 40 of the encoder chip 42 experience a relatively uniform magnetic field distribution from whichever pole of the magnet 38 is closest. Such an encoder chip 42 can have a greater or lesser number of Hall sensors. For example, such an encoder chip 42 can be equipped with as few as four Hall sensors.

[0054] A couple of preferred examples of a commercially available contactless rotary magnetic encoder chip having such a construction include an AS5040 and AS5046 rotary magnetic angle encoder integrated circuit chip made by Austria Microsystems of Tobelbaderstrasse 30, Schloss Premstaetten, Unterpremstaetten, Austria. The AS5046 is a 16 pin integrated circuit (IC) that includes an onboard array of Hall sensors, H<sub>0</sub>-H<sub>7</sub>, onboard amplifier therefor, onboard digital signal processor, onboard automatic gain control, onboard range pre-select, an onboard OTP register, an onboard digital to analog converter, and an onboard interface. Other examples of commonly used magnetic encoder chips of similar construction include an AS5040 10-bit programmable magnetic rotary encoder IC chip, an iC-MA Angular Hall Encoder chip made by iC Hause Integrated Circuits of Am Kuemmerling 18, 55294 Bodenheim, Germany, as well as an AM256 rotary magnetic encoder IC chip by Renishaw plc of New Mills, Wotton-under-Edge, Gloucestershire, United Kingdom.

[0055] As a result, the distance, Z, of the exciter magnet 38 from the outer surface 58 of the encoder chip 42 (and hence the distance of the magnet 38 from the array of Hall sensors, H<sub>0</sub>-H<sub>7</sub>), must be within an acceptable distance range depending on the field strength of the magnet 38 and the center of the magnet 38 (and rotational axis 66 of shaft 36) must be within an acceptable range of the center point 68 of the sensor region 40 of the encoder chip 42 or errors will undesirably result. For example, such errors can be in the form of increased signal noise in the output signal. Where a pair of offset sine or square waves is outputted by the encoder chip 42, such errors can be in the form of an erroneous increase or decrease in the offset. Where this offset is determinative of the rotational angle of the exciter magnet 38, any such error will obviously result in an erroneous rotational angle.

### First Preferred Rotary Magnetic Encoder Assembly Embodiment

[0056] FIGS. 6-15 illustrate a first preferred embodiment of a misalignment and mislocation tolerant non-contact rotary

magnetic encoder assembly **80a'** and **80a''** constructed in accordance with the present invention. Two similar variants of the encoder assembly **80a'** and **80a''** are shown in FIG. 6 and FIG. 7 with the variant **80a'** shown in FIG. 6 having a single rotary encoder shaft **82a** and the variant **80a''** having its bearing-less rotary encoder shaft **82b** connected by a physical coupling **84**, such as a flexible coupling or the like, to another shaft **86** through which rotary motion is communicated to the encoder shaft **82b**. To provide a greater amount of tolerance to angular misalignment, radial misalignment, and/or spacing mislocation of the encoder shaft **82a** or **82b** relative to the encoder chip **42** than conventional prior art rotary magnetic encoders, the encoder shaft **82a** or **82b** carries a drive coupler arrangement **87a** that magnetically couples with a free-wheeling exciter magnet **38** that is held captive within the encoder assembly **80a'** or **80a''** so as to ensure consistent, suitable spacing and accurate radial location of the exciter magnet **38** relative to the sensor region **40** (FIG. 8) of the encoder chip **42** during operation of the rotary magnetic encoder assembly **80a'** or **80a''**. In the preferred embodiment shown in FIGS. 6 and 7, the drive coupler arrangement **87a** is a drive magnet **88** that magnetically couples with the exciter magnet **38** for rotation in unison therewith once complete coupling is achieved. As a result, at least one preferred embodiment of a rotary magnetic encoder assembly, e.g., encoder assembly **80a'** and **80a''**, constructed in accordance with the present invention is less expensive to construct because does not have any shaft bearings as none are required.

**[0057]** Rotary magnetic encoder assemblies **80a'** and **80a''** each have a "puck" shaped encoder body **90** that carries the exciter magnet **38** and a circuit board **92** that includes onboard electronics **94** and encoder chip **42**. As is best shown in FIGS. 8-11, the encoder body **90** has a first generally cylindrical recess **96** of generally counterbore construction having an annular flat mounting surface **98** about its outer periphery to which the circuit board **92** is mounted using fasteners **100**. If desired, the mounting surface **98** can have bores **106** in it configured to facilitate fastener engagement and be bounded by an annular axially-extending sidewall **108** in which additional fastener-receiving bores **110** are formed. The encoder body **90** has a second recess **102** that is a clearance recess in which the encoder chip **42** is disposed when the circuit board **92** is mounted to the encoder body **90**. The second recess is also annular or generally cylindrical but can be formed having a different shape, such as one which is complementary to the shape of the encoder chip **42**. The encoder body **90** also has a generally cylindrical magnet-holding pocket **104** formed in it that overlies the sensor region **40** (FIG. 8) of the encoder chip **42** when the circuit board **92** is mounted to the encoder body **90**. As is best shown in FIGS. 8 and 10, the magnet pocket **104** is defined by a mouth **111**, an endless circular sidewall **112** and an end-wall **114**.

**[0058]** If desired, there can be an adhesive or protective coating, cover or the like (not shown in FIGS. 6-15) that overlies the encoder chip **42** between the chip **42** and exciter magnet **38**. There also can be a layer of low friction material (also not shown in FIGS. 6-15) disposed between the magnet **38** and chip **42** to minimize the friction the exciter magnet **38** experiences when being rotated relative to the encoder body **90** and relative to the encoder chip **42** by the drive magnet **88** during encoder operation. Where an adhesive or protective coating or cover is used, the low friction layer preferably is located between the adhesive or protective coating or cover and the magnet **38**.

**[0059]** As is best shown in FIG. 11, the opposite side of the encoder body **90** can be configured with a recessed generally flat or planar end-wall **116** bounded by an axially-extending sidewall **118**. If desired, the sidewall **118** can include a plurality of circumferentially spaced apart fastener-receiving bores **120**. As is shown in FIGS. 6 and 7, at least part of this end-wall **116** overlies and/or defines part of the magnet pocket **104**.

**[0060]** With reference to FIG. 6, encoder assembly **80a'** can include an outer housing **122** (shown in phantom in FIG. 6), such as in the case where either shielding is desired or where additional protection and/or ruggedness is desired. Where the outer housing **122** overlies any portion of encoder body end-wall **116**, it can be configured with a bore **124** through which encoder shaft **82a** can extend. Depending on requirements, where an outer housing is employed, such an outer housing can be made of metal, such as anodized aluminum, non-magnetic stainless steel, or the like, but can also be constructed of plastic or another synthetic or non-metallic material. Outer housing **122** can be attached to the encoder body **90** by a plurality of fasteners **126** and can be equipped with mounting bores (not shown) that can be threaded for facilitating mounting the encoder assembly **80a'** to something else, such as an equipment frame, etc. If desired, where an outer housing is employed, it can have a different shape or configuration than that depicted in FIG. 6. For example, such a housing can be constructed to cover, enclose or otherwise overlie part of or all of the circuit board **92**. It also should be noted that use of a housing is not limited for use with only the encoder assembly **80a'** shown in FIG. 6, but can be used with other encoder assemblies constructed in accordance with the present invention. Finally, although the magnet pocket **104** is formed in the encoder body **90**, it can be formed as part of the housing **122** or as part of some other component otherwise attached to the housing **122**, such as where an encoder assembly lacks structure that corresponds to encoder body **90**.

**[0061]** The circuit board **92** is attached to the encoder body **90** using fasteners **100**. Circuit board **92** can be the same as or similar to previously-discussed circuit board **44** used in the conventional prior art rotary magnetic encoder **30** shown in FIGS. 1-4. Like circuit board **44**, circuit board **92** includes onboard electronics **94** used to process data and/or signals from the encoder chip **42** to produce an encoder output that is communicated via a cable (not shown) attached to a connector **128**, such as a multiple pin Molex-type socket or the like, to an external device, such as a computer, controller or another type of processor (not shown), which uses encoder output in accordance with the application for which the encoder assembly **80a'** or **80a''** is being used. For example, where used in determining log cut length for a tree feller, tree harvester, or the like, encoder output from connector **128** is communicated to a controller (not shown) that makes a cut length determination or estimation using the encoder output.

**[0062]** Where an electrical power source is not provided onboard the encoder assembly **80a'** or **80a''**, the connector **128** can also include power supply inputs, such as from an external electrical power source, for communicating electrical power to the encoder chip **42** as well as the other onboard electronics **94**. Although a cable connector **128** is shown in FIGS. 6 and 7, the present invention contemplates that other types of connectors, sockets, links and the like, both of hard-wire and wireless construction, can be used to communicate encoder output. In addition, such communication can be uni-directional or bi-directional.

[0063] The circuit board 92 is fixed to the encoder body 90 in a manner that locates the encoder chip 42 over the magnet pocket 104 capturing the exciter magnet 38 in the pocket 104. The encoder chip 42 is precisely located on the circuit board 92 and the circuit board 92 is precisely located relative to the encoder body 90 when fixed to the body 90. As a result, the magnet pocket 104 is precisely located relative to the sensor region 40 of the encoder chip 42 such that an exciter magnet 38 received in the pocket 104 is also precisely located relative to the sensor region 40 of the encoder chip 42. More specifically, the center 61 of the exciter magnet 38 is maintained substantially coaxial with the center 68 of the sensor region 40 of the encoder chip 42 by capturing the magnet 38 in the pocket 104. Precisely locating the exciter magnet 38 in this manner advantageously ensures that the sensor region 40 of the encoder chip 42 experiences a substantially uniform magnetic field distribution from the exciter magnet 38 at all times during encoder operation. This advantageously minimizes, if not prevents, encoder chip errors relating to mislocation and angular misalignment that occurred in the past with conventional prior art magnetic encoders where the exciter magnet was mounted to the rotary encoder shaft, i.e. shaft 36 (FIGS. 1-4).

[0064] During operation of a rotary magnetic encoder constructed in accordance with the present invention, the exciter magnet 38 is driven by the drive magnet 88, which is carried by encoder shaft 82a or 82b and located close enough to the exciter magnet 38 to magnetically couple with the magnet 38 even though the two magnets 38, 88 do not directly contact one another. The drive magnet 88 can be disk-shaped the same as or similar to that of the exciter magnet 38. The drive magnet 88 has at least two poles 130, 132 with the line of intersection of the poles 130, 132 bisecting the magnet 88 as shown in FIG. 8. In the preferred embodiment shown in FIGS. 6-8, the drive magnet 88 is disk-shaped, received in a pocket 134 formed in the axial free end of the encoder shaft 82a or 82b, and has a center 136 that is generally coaxial with an axis 138 of rotation of the encoder shaft 82a or 82b. In the preferred embodiment shown in FIGS. 6-8, the drive magnet 88 is fixed to the encoder shaft 82a or 82b so the magnet 88 rotates in unison with the shaft 82a or 82b. Such a magnet 88 can be fixed by being press fit into the pocket 134 or adhesively attached to the encoder shaft 82a or 82b. Other means of attachment can be used including means of attachment, e.g., adhesive attachment, where pocket 134 is not required.

[0065] The magnet pocket 104 preferably is of low-friction construction to allow the exciter magnet 38 to rotate substantially in unison with the drive magnet 88 when the drive magnet 88 is located in close enough proximity where magnetic coupling takes place. To achieve a suitably low-friction pocket construction, at least the endless pocket sidewall 112 and end-wall 114 are constructed of a material having a low enough static coefficient of friction that the exciter magnet 38 is urged into rotation as the drive magnet 88 is rotated by the encoder shaft 82a or 82b. Such a material has a low enough dynamic coefficient of friction that such coupling between the magnets 38, 88 due to encoder shaft rotation results in the exciter magnet 38 rotating substantially in unison with the drive magnet 88. In addition, the pocket sidewall 112 and end-wall 114 are suitably smooth to reduce friction during exciter magnet rotation. To facilitate magnetic coupling of the drive magnet 88 with the exciter magnet 38, the material of the pocket end-wall 114 is made of a material that also has a sufficiently low magnetic permeability that flux lines of the

magnetic fields of the magnets 38, 88 extend through the encoder body material in the region of the pocket end-wall 114 of sufficient strength and/or density so that the magnets 38, 88 efficiently couple in a manner where exciter magnet 38 can eventually if not nearly immediately rotate in unison with the drive magnet 88 in response to rotation of the encoder shaft 82a or 82b. In a preferred embodiment, the pocket sidewall and end-wall material along with the magnets 38 and 88, including their field strengths, are selected so that there is a desirably low coefficient of friction, a suitably low magnetic permeability and suitably high magnetic field strength so that the exciter magnet 38 can achieve coupling with the drive magnet 88 very quickly after the drive magnet 88 begins to rotate such that the exciter magnet 38 rotates in unison with the drive magnet 88 at the same rotational speed as the encoder shaft 82a or 82b during operation. As a result of such drive magnet—driven exciter magnet coupling, a greater degree of angular misalignment of the encoder shaft relative to the center of the exciter magnet and the center of the sensor region of the encoder chip is tolerable.

[0066] In at least one embodiment, at least the material in the region of the pocket end-wall 114 is a non-ferromagnetic material, e.g., DELRIN, having a relative permeability no greater than twice that of a vacuum. Such a low permeability material can have a somewhat higher permeability depending on factors such as magnetic field strength and/or flux density of the magnets 38, 88, the spacing between the magnets 38, 88, maximum encoder shaft rotational speed likely to be encountered, as well as quite possibly other factors.

[0067] As is most clearly shown in FIGS. 6 and 7, the encoder chip 42 is positioned so it overlies the mouth 111 of the magnet pocket 104 in a manner that essentially “caps” the pocket thereby capturing the exciter magnet 38 in the pocket 104. This prevents the exciter magnet 38 from being removed or otherwise inadvertently falling out of the pocket 104 unless the circuit board 92 is intentionally disassembled from the encoder body 90. The encoder chip 42 can also be and preferably is constructed of a low friction material as, in a currently preferred embodiment; the chip 42 is of dual-inline package (DIP) construction packaged in a ceramic or plastic material thereby minimizing frictional losses should the exciter magnet 38 come into contact with the outer surface of the package of the chip 42 during magnet rotation. Such low friction pocket and chip construction along with low magnetic permeability in the space between the magnets 38, 88 advantageously helps ensure that coupling between the magnets 38, 88 is maintained even at rotational speeds greater than 1,000 revolutions per minute (rpm) and, in at least some instances, even at rotational speeds greater than about 5,000 rpm.

[0068] With reference once again to FIGS. 9-11, the encoder body 90, including the material of the encoder body 90 that defines pocket sidewall 112 and outer encoder body end-wall 116, is made of plastic, such as a thermoplastic like DELRIN, nylon, aluminum, or another suitable material having a magnetic permeability and coefficient of friction that is low enough to permit coupling of the magnets 38, 88 and to maintain that coupling at rotational speeds of greater than 1,000 rpm. In a currently preferred embodiment, the encoder body 90 is made of DELRIN having the magnet pocket 104 formed using a conventional material removal process but which can also be integrally molded into the encoder body 90 if desired. In another preferred embodiment, the encoder body 90 can be made of anodized aluminum with the magnet

pocket 104 formed by machining or another material removal process as anodized aluminum possesses both a suitably low magnetic permeability and low coefficient of friction.

[0069] FIGS. 12-15 illustrates how the exciter magnet 38 self-locates when the drive magnet 88 attached to the encoder shaft 82a is brought close enough to cause the magnets 38, 88 to couple. FIG. 12 illustrates the exciter magnet 38 abutting against the encoder chip 42, such as what can occur in the absence of any magnetic field of the drive magnet 88 when gravity pulls the exciter magnet 38 on top of the encoder chip 42. FIG. 13 illustrates bringing the encoder shaft 82a toward the encoder body 90 and the exciter magnet 38 causing magnetic field interaction between the drive magnet 88 and exciter magnet 38 that causes the exciter magnet 38 to begin moving toward the pocket end wall 114 and the drive magnet 88. FIG. 14 shows the encoder shaft 82a located close enough to encoder body 90 and exciter magnet 38 causing interaction between the magnetic field of the drive magnet 88 and the magnetic field of the exciter magnet 38 to pull the exciter magnet 38 against the pocket end wall 114 while the magnets 38, 88 also become magnetically coupled. With reference to FIG. 15, the pocket end wall 114 provides an abutment surface for the exciter magnet 38 that also accurately locates the magnet 38 relative to the encoder chip 42 such that the exciter magnet 38 is spaced apart a desired and acceptable distance, Z, such that the sensor region 40 of the encoder chip 42 will experience a substantially uniform magnetic field during encoder operation. Because the pocket sidewall 112 is sized slightly larger than the exciter magnet 38, it prevents the magnet 38 from flipping during this axial location and magnetic coupling process while also radially locating the exciter magnet 38 relative to the sensor region 40 of the encoder chip 42 so that the center 61 of the exciter magnet 38 is substantially coaxial or substantially aligned with the center 68 of the sensor region 40 of the encoder chip 42.

[0070] As previously discussed, the exciter magnet 38 can be a rare earth magnet, such as an alnico magnet, a samarium cobalt magnet, or a neodymium magnet having a suitably high magnetic flux density that provides the sensor region 40 of the encoder chip 42 with a substantially uniform magnetic field during encoder operation when maintained captive in the magnet pocket 104 in the encoder body 90. In a preferred embodiment, the exciter magnet 38 is an alnico magnet, a samarium cobalt magnet, or a neodymium magnet specifically designed for use with the particular encoder chip 42 used in the rotary magnetic encoder assembly 80a' or 80a". Such an exciter magnet 38 can have a diameter of about 6 mm and a height or thickness of no more than about 2.5 mm. It is of bipolar construction, being axially bisected in a manner that divides the magnet 38 in half such that one half is a North Pole 62 and the other half is a South Pole 64. Routine testing and experimentation can be used to select an exciter magnet having characteristics differing from that described above but which optimizes its performance with the encoder chip 42 and the drive coupler 87, e.g., drive magnet 88, employed.

[0071] The drive magnet 88 can also be a rare earth magnet, such as an alnico magnet, a samarium cobalt magnet, or a neodymium magnet. In the preferred embodiment shown in FIGS. 6-8 and 13-15, the drive magnet 88 can be the same as or similar to the exciter magnet 38. For example, in the preferred embodiment shown in FIGS. 6-8 and 13-15, the drive magnet 88 is a disk-shaped rare earth magnet of bipolar construction having one half that is a South pole 130 and another half that is a North pole 132. While the drive magnet

88 is shown in FIGS. 6-8 and 13-15 as being roughly the same size as the exciter magnet 38, the drive magnet 88 can be somewhat larger or slightly smaller than the exciter magnet 38. As with the exciter magnet 38, similar routine testing and experimentation can be employed to select a drive magnet 88 having optimal properties in view of the application, distance between it and the exciter magnet 38, the magnetic permeability of the material between it and the exciter magnet, etc.

[0072] FIGS. 16-20 are schematic diagrams that illustrate operation of a rotary magnetic encoder assembly 80a' or 80a" constructed in accordance with the present invention and which also highlight more clearly its ability to tolerate angular misalignment and mislocation of the drive magnet 88 relative to the exciter magnet 38 while maintaining magnetic coupling therebetween.

[0073] FIG. 16 illustrates magnetic coupling of a rotary magnetic encoder assembly constructed in accordance with the present invention where the exciter magnet 38 is accurately radially aligned with the sensor region 40 of the encoder chip 42 (not shown in FIG. 16) such that its center 61 about which it rotates when magnetically coupled to the drive magnet 88 is substantially coaxial and aligned with the center 68 of the encoder chip sensor region 40. As is also shown in FIG. 16, the exciter magnet 38 is optimally spaced apart a distance, Z, from the encoder chip sensor region 40 thereby ensuring that the sensor region 40 experiences a substantially uniform magnetic field from the exciter magnet 38. In this example, the drive magnet 88 is fixed to the encoder shaft 82a such that it rotates in unison therewith with the drive magnet 88 having its center 136 substantially coaxial with the encoder shaft axis of rotation and generally aligned with the center 61 of the exciter magnet 38 and the center 68 of the encoder chip sensor region 40. In addition, the drive magnet 88 is optimally spaced a distance, D<sub>1</sub>, from the exciter magnet 38 ensuring good magnetic coupling between magnets 38 and 88.

[0074] During operation, rotation of the encoder shaft 82a rotates the drive magnet 88 with the drive magnet 88 magnetically coupling with the exciter magnet 38 when the North pole of the drive magnet 88 overlies or aligns with the South pole of the exciter magnet 38 in the South pole of the drive magnet 88 overlies or aligns with the North pole of the exciter magnet 38. When this occurs, the drive magnet 88 causes the exciter magnet 38 to rotate in unison with the encoder shaft 82a thereby causing its magnetic fields to interact with the Hall sensors of the encoder chip sensor region 40 in a manner that accurately outputs a signal indicative of (1) encoder shaft angle, and/or (2) the rotational speed of the encoder shaft 82a, such as in revolutions per minute, radians per second, or the like.

[0075] FIG. 17 illustrates that the radial location of the exciter magnet 38 along with its ideal spacing, Z, from the encoder chip sensor region 40 always remains optimum despite the fact that its distance, D<sub>2</sub>, from the drive magnet 88 is greater than D<sub>1</sub> and greater than Z. This example demonstrates an advantage of the present rotary magnetic encoder assembly 80a' or 80a" in that it is significantly more tolerant to spacing changes than the aforementioned conventional prior art rotary magnetic encoders. Depending on magnetic field strength of the drive magnet 88 as well as that of the exciter magnet 38, the spacing, D, between the magnets 38, 88 can vary as much as 50% or about 35 millimeters while maintaining sufficient magnetic coupling that the exciter

magnet **38** will rotate in unison with the drive magnet **88** and hence with the encoder shaft **82a**.

[0076] FIG. 18 illustrates that the angular alignment of the drive magnet **88** relative to the exciter magnet **38** can be off such that there is angular misalignment therebetween. As is shown in FIG. 18, the axis of rotation of the encoder shaft **82a** passes through the center **136** of the drive magnet **88** as well as through the center **61** of the exciter magnet **38** but diverges from an axis of alignment between the center **61** of the exciter magnet **38** and the center **68** of the encoder chip sensor region **40** by an angle,  $\alpha_1$ . Even though there is angular misalignment, coupling between the drive magnet **88** and the exciter magnet **38** is maintained such that the exciter magnet **38** rotates substantially in unison with the drive magnet **88** and the encoder shaft **82a**. In a preferred embodiment, a rotary magnetic encoder assembly **80a'** or **80a''** constructed in accordance with the present invention can tolerate an angular misalignment,  $\alpha$ , of as much as  $30^\circ$  so long as the distance,  $D$ , between the magnets **38**, **88** is close enough to achieve magnetic coupling.

[0077] FIG. 19 also illustrates angular misalignment tolerance but the ability to adequately maintain magnetic coupling decreases as the distance,  $D_2$ , between the magnets **38**, **88** increases. In this case,  $D_2$ , is greater than  $D_1$  and  $Z$  and  $\alpha_2$  is less than  $\alpha_1$ . FIG. 20 illustrates the case where the drive magnet **88** is both radially offset and angularly misaligned such that the axis of rotation of the encoder shaft **82a** passes through the center **136** of the drive magnet **88** but does not pass through the center **61** of the exciter magnet **38** with the angle,  $\alpha_3$ , between the axis of encoder shaft rotation and an axis extending between the center **61** of the exciter magnet **38** in the center **68** of the encoder chip sensor region **40** being as much as  $30^\circ$  so long as the distance,  $D$ , between the magnets **38**, **88** is close enough to achieve magnetic coupling.

[0078] FIG. 21 illustrates another preferred drive coupling embodiment where the drive coupler **87b** includes a pair of drive magnets **88a** and **88b** mounted to a cylindrical encoder shaft **82c** that cooperate with the sensor exciter magnet **38** to magnetically couple with the exciter magnet **38**. The magnets **88a** and **88b** are disposed opposite one another such that they are approximately  $180^\circ$  apart with one of the magnets **88a** having its North pole facing axially outwardly generally toward the encoder assembly **80a'** and the other one of its magnets **88b** having its South pole facing axially outwardly generally toward the encoder assembly **80a'**. When coupling occurs, magnetic flux lines extend between the North pole of magnet **88a** and the South pole **64** of the exciter magnet **38** and magnetic flux lines extend between the South pole of magnet **88b** and the North pole **62** of the exciter magnet **38**. In another preferred embodiment, the magnets instead can be radially disposed with one of the magnets **88a'** (shown in phantom in FIG. 21) having its North pole facing generally radially inwardly toward the South pole of the other one of the magnets **88b'**.

[0079] While magnets **88a** and **88b** are shown mounted in an axially outer surface of a generally cylindrical encoder shaft **82c**, the encoder shaft can be a rod that is attached to an annular ring or collar that carries magnets **88a** and **88b**. Depending on the strength of magnets **88a** and **88b**, the diameter of such a shaft, ring or collar carrying magnets **88a** and **88b** can be made larger than shown in FIG. 21. For example, if desired, the diameter of such a shaft, ring or collar can be made large enough such that the inner diameter is larger than the outer diameter of the encoder body **90** enabling at least a

portion of the encoder body **90** to be received within the shaft, ring or collar. While permanent magnets **88a** and **88b** are shown in FIG. 21, it should be noted that they could instead be electromagnets or an electromagnet arrangement carried by the encoder shaft **82c** that causes regions corresponding to **88a** and **88b** to respectively produce North and South pole fields.

[0080] FIG. 22 illustrates another embodiment of a drive coupler **87c** that is similar to the drive coupler **87b** of FIG. 21 but which utilizes a plurality of pairs, i.e., at least three, of drive magnets. For example, there are eight drive magnets **88a-h** disposed about the circumference of the axial surface of encoder shaft **82c**. Preferably, there are at least a plurality of North pole facing magnets, e.g., **88a**, **88c**, **88d**, and **88e**, and at least a plurality of South pole facing magnets, e.g., **88b**, **88f**, **88g**, and **88h**, that couple in a manner similar to that discussed above with regard to FIG. 21. Of course, if desired, one or more of these drive magnets can be radially disposed.

[0081] FIG. 23 illustrates still another embodiment of a drive coupler **87d** where encoder shaft **82d** is made of a ferromagnetic or paramagnetic material or ferromagnetic/paramagnetic material is disposed at the end of the shaft **82d** with the end of the shaft **82d** located in such close proximity to the exciter magnet **38** that the magnetic attraction of the ferromagnetic/paramagnetic material to the exciter magnet **38** effectively couples the magnet to the shaft causing the exciter magnet **38** to rotate in unison with the encoder shaft **82d** when this occurs. If desired, the shaft **82d** can be of permanent or electromagnet construction having just a single pole at its free end **89** that is disposed adjacent the exciter magnet **38** such that coupling of flux lines between the pole and the opposite pole of the exciter magnet **38** achieves sufficient magnet coupling for rotation of the exciter magnet **38** in unison with the shaft **82d**.

#### Second Preferred Rotary Magnetic Encoder Assembly Embodiment

[0082] FIGS. 24-26 illustrate a second preferred embodiment of a rotary magnetic encoder assembly **80b** constructed in accordance with the present invention. The encoder assembly **80b** includes an outer tubular shell **140** that can be made of metal, such as aluminum or the like, which houses an encoder circuit assembly **142** that includes a circuit board, **143**, interface electronics **94**, a connector **128** and magnetic rotary encoder integrated circuit chip **42**, an encoder body or base **144** and an exciter magnet holder **146** that holds the exciter magnet **38** in a manner that precisely locates it relative to the encoder chip **42**. There can be an adhesive cover **148** disposed between the encoder chip **42** and exciter magnet **38** as best shown in FIG. 26. In addition, there also can be a low friction cap **150** that is a relatively thin layer of a relatively low friction material such as TEFLON, nylon, or another relatively low friction material that facilitates free spinning movement of the exciter magnet **38** in the magnet holder **146** when coupled with the encoder shaft **82e**. In the preferred embodiment shown in FIGS. 24-26, the rotary magnetic encoder assembly **80b** has an adhesive cover **148** that overlies the encoder chip **42** and a low friction material layer **150** disposed between the encoder chip **42** and the exciter magnet **38**.

[0083] The magnet holder **146** is an insert that is received in a recess **152** formed in the encoder base **144** such that when the encoder assembly **80b** is assembled, the magnet holder **146** is disposed in engagement with the encoder base **144** with

one end of the holder **146** is disposed adjacent the encoder chip **42**. The recess **152** communicates with an opening **154** formed in the encoder base **114** through which part of the encoder shaft **82e** extends during encoder operation. The magnet holder **146** has a magnet-holding and locating pocket **156** formed in one end and a low friction coupling guide bore **158** formed in its other end with an end wall **160** disposed therebetween. As is shown in FIG. 25, a portion of the encoder shaft **82e** that carries the drive magnet **88** is received in the low friction coupling guide bore **158**. The magnet holder **146** preferably is made of a material having a relatively low magnetic permeability, such as DELRIN or the like, to optimize magnetic coupling between the drive magnet **88** and exciter magnet **38** by minimizing any reduction in magnetic flux density therebetween. When encoder assembly **80b** is assembled, the low friction cap **150** overlies the pocket **156** and the exciter magnet **38** as shown in FIG. 25.

[0084] The encoder shaft **82e** is an elongate biasing element **162** that preferably is a coil spring that holds the drive magnet **88** at its free end with its free end and magnet **88** received in the low friction coupling guide bore **158** during encoder operation. It includes a coupling collar **164** at its opposite end that mates with a rotating element **166** (shown in phantom in FIG. 25) causing the encoder shaft **82e** to rotate in unison with the rotating element **166** during operation. Use of biasing element **162** advantageously accommodates a great deal of axial, radial and angular play making use of this type of encoder shaft **82e** well suited for applications where the rotating element **166** may move axially toward or away from the encoder assembly **80b**, radially relative to the encoder assembly **80b**, as well as angularly relative to the encoder assembly **80b** (as well as a combination of all three) during operation. The length of the biasing element **162** can be and preferably is selected so that it is captured in compression during operation in the low friction coupling guide bore **158** between the magnet holder **146** and the rotating element **166** based on the distance therebetween.

#### Third Preferred Rotary Magnetic Encoder Assembly Embodiment

[0085] FIG. 27 illustrates a third preferred embodiment of a rotary magnetic encoder assembly **80c** that includes an elongate outer tubular shell **168** which houses an elongate carriage **170** that holds the interface electronics, the connector and encoder chip **42** that is capped by a magnet holding encoder body **172** made of a low friction material that also has a low magnetic permeability. The magnet holder **172** has a pocket **174** in which the exciter magnet **38** is received. When the magnet holder **172** is disposed in the shell **168**, it ensures accurate positioning of the exciter magnet **38** relative to the encoder chip **42**. If desired, a low friction layer **176** and adhesive or protective layer **178** can be disposed between the exciter magnet **38** and the encoder chip **42**.

[0086] The encoder shaft **82f** can be constructed the same as or similar to any of the encoder shaft constructions discussed previously herein. In the preferred embodiment shown in FIG. 27, the encoder shaft **82f** includes a rod **180** of non-magnetic construction that holds the drive magnet **88** in its free end. Where made of a non-magnetic metal, it can be made of a non-magnetic stainless steel, bronze or the like, with the magnet **88** press fit into a pocket formed in the free end of the rod **180**. Where the rod is made of a magnetic metal, the magnet **88** is magnetically isolated from the rod using a

non-magnetic bushing (not shown) that is disposed in the free end of the rod, such as by press-fitting or the like.

#### Rotary Magnetic Encoder Chip

[0087] FIG. 28 illustrates a preferred embodiment of a rotary magnetic encoder chip **182** constructed in accordance with the present invention that has a package body **184** formed with an integral exciter magnet holding pocket **186** in which a rotatable exciter magnet **188** is held captive. The encoder chip package body **184** houses at least a plurality of Hall sensors **190** arranged in a Hall sensor array **192** that also defines an encoder chip sensor region **196** along with additional onboard electronic circuitry, such as onboard analog-to-digital converter circuitry (not shown) as well as digital signal processing circuitry (not shown). Although only two Hall sensors **190** are shown in FIG. 28, rotary magnetic encoder chip **182** preferably has an array of at least four such sensors **190** and can have as many as eight or more sensors arranged in an array the same as or like the arrangement of Hall sensors,  $H_0$ - $H_7$ , shown in FIG. 5 defining a similarly configured sensor region. Extending from the package body **184** are a plurality of pairs of electrically conductive pins **194** that can be soldered to a circuit board or which can be inserted into a socket, such as preferably a DIP integrated circuit socket (not shown) or the like. Thus, a rotary magnetic encoder chip **182** equipped with an integral rotatable exciter magnet **188** constructed in accordance with the present invention can and preferably has a DIP footprint, though its package height might be greater than a standard integrated circuit of DIP construction.

[0088] The pocket **186** is annular or disk-shaped and is located relative to the Hall sensors **190** so as to center the exciter magnet **188** over the sensor region and position it above the sensors so they experience a substantially uniform magnetic field from the exciter magnet when it is rotated, such as by a drive magnet, e.g., drive magnet **88**, during operation. Exciter magnet **188** is annular or disk shaped and can be a rare earth magnet, such as an alnico, samarium cobalt or neodymium magnet.

[0089] The encoder chip package body **184** can be molded, cast, pressed, or otherwise formed of a relatively low friction material that also has a low magnetic permeability to enable the exciter magnet **188** to rotate freely in the pocket **186** when coupling with an external magnetic field or other drive coupling occurs. Such materials include at least some ceramic materials as well as some plastics, including DELRIN and the like. If desired, the pocket **186** can be lined with a low friction material, such as TEFLON or the like, that reduces friction to facilitate exciter magnet coupling as well as to increase ease of exciter magnet rotation once coupling has been achieved. If desired, the package body **184** can be of layered construction (not shown) where at least a portion of the package body **184** located above the exciter magnet **188** is made of a material having low magnetic permeability.

[0090] In one preferred embodiment, the pocket **186** is integrally formed in the package body **184** of the encoder chip **182** during manufacture of the encoder chip **182** with the exciter magnet **188** disposed in the pocket **186** as part of the encoder chip manufacturing process. This is done at the encoder chip manufacturing or fabrication plant.

[0091] In another preferred embodiment, a layer is molded onto the package body of a conventional rotary magnetic encoder chip, e.g. encoder chip **42** such that the pocket **186** is integrally formed in the layer molded onto the package body.

Preferably, the exciter magnet **188** is positioned within the pocket **186** before or at the time the pocket **186** is formed and/or when the layer is molded. If desired, this can be done during encoder chip manufacture or after encoder chip manufacture, including at a site remote from the encoder chip manufacturing or fabrication plant.

[0092] FIG. 29 illustrates use of the rotary magnetic encoder chip **182** with an encoder assembly **80d** constructed similar to the encoder assembly **80a'** shown in FIG. 6. Encoder ship **182** is attached to circuit board **92** and located so its exciter magnet **188** is adjacent to and generally aligned with drive magnet **88** of encoder shaft **82a** of drive coupler **87** so that the exciter magnet **188** couples with drive magnet **88** during encoder shaft rotation for rotation at the same rotational speed as the shaft **82a**. Operation is same or similar to that of encoder assembly **80a'**.

#### Rotary Magnetic Encoder Chip Exciter Magnet Module

[0093] FIGS. 31-33 illustrate the construction, use and operation of an exciter magnet module **200** that is mountable to a rotary magnetic encoder chip of conventional construction, such as encoder chip **42**. Such a module **200** can be releasably mountable, such as by being of clip-on construction, but can also be adhesively attached if desired. Module **200** has a body **202** made of a material having a suitably low magnetic permeability in which an exciter magnet holding pocket **204** of annular construction is formed that holds captive a rotatable disk-shaped exciter magnet **206**.

[0094] In one preferred embodiment, the body **202** of the module **200** is made of DELRIN but can be made of another material having suitably low magnetic permeability. DELRIN is an example of a preferred exciter magnet module body material because it also possesses low friction such that it facilitates efficient coupling of the exciter magnet **206** with an external drive coupler, e.g., drive magnet **88** or the like, and advantageously enables such coupling to be maintained even at relatively high encoder shaft rotational speeds.

[0095] To facilitate accurate location of the module **200** on the chip **42** such that the exciter magnet **206** overlies the Hall sensors, H, of the sensor region **40** of the chip, there is at least a plurality of pairs of side locator tabs **208** and at least a plurality of end locator tabs **210** that respectively engage the sides and ends of a DIP package of encoder chip **42**. Tabs **208** and **210** can be configured to relatively tightly frictionally engage the package body of the encoder chip **42** in a manner that enables the module **200** to be "clipped" onto the encoder chip **42**. If desired, even where the locator tabs **208** and **210** frictionally engage the encoder chip **42**, an adhesive can be applied to either the encoder chip or the module **200** to adhesively fix the module **200** to the chip **42**. For example, adhesive, such as an epoxy or the like, can be applied in the space between the chip **42** and module **200** designated by reference numeral **212** in FIGS. 32 and 33.

[0096] It is understood that the various preferred embodiments are shown and described above to illustrate different possible features of the invention and the varying ways in which these features may be combined. Apart from combining the different features of the above embodiments in varying ways, other modifications are also considered to be within the scope of the invention.

1. A rotary magnetic encoder assembly comprising:

- (a) a magnetic field sensor arrangement;
- (b) a rotatable magnet disposed adjacent the magnetic field sensor arrangement and having a magnetic field that is sensible by the magnetic field sensor arrangement; and
- (c) a rotary encoder shaft that effects rotation of the rotatable magnet without contacting the rotatable magnet.

2. The rotary magnetic encoder assembly of claim 1 wherein the rotary encoder shaft causes rotation of the rotatable magnet by interaction with a magnetic field of the rotatable magnet.

3. The rotary magnetic encoder assembly of claim 2 wherein the rotary encoder shaft is spaced from the rotatable magnet.

4. The rotary magnetic encoder assembly of claim 3 wherein the rotary encoder shaft comprises a drive coupler that provides contactless coupling with the rotatable magnet causing the rotatable magnet to rotate when the rotary encoder shaft rotates.

5. The rotary magnetic encoder assembly of claim 4 wherein the drive coupler comprises a drive magnet spaced close enough to the rotatable magnet that magnetic coupling therebetween is achieved.

6. The rotary magnetic encoder assembly of claim 5 wherein the drive magnet is at or adjacent a free end of the encoder shaft.

7. The rotary magnetic encoder assembly of claim 1 further comprising an encoder housing or encoder body and wherein no bearing of the rotary magnetic encoder assembly rotatively supports the encoder shaft.

8. The rotary magnetic encoder assembly of claim 7 wherein there is no bearing that is mounted, attached or otherwise carried by the encoder housing or the encoder body that rotatively supports the encoder shaft.

9. The rotary magnetic encoder assembly of claim 1 further comprising an encoder housing or encoder body and wherein the encoder shaft rotates relative to the encoder housing or encoder body without being rotatively supported thereby.

10. The rotary magnetic encoder assembly of claim 1 further comprising a magnet retainer that locates the rotatable magnet relative to the magnetic field sensor arrangement.

11. The rotary magnetic encoder assembly of claim 10 wherein the magnet retainer locates the rotatable magnet axially and radially relative to the magnetic field sensor arrangement.

12. The rotary magnetic encoder assembly of claim 11 wherein the magnet retainer comprises a magnet-holding pocket whose location is fixed relative to the magnetic field sensor arrangement.

13. The rotary magnetic encoder assembly of claim 11 wherein the magnet retainer comprises one of an encoder body and encoder housing.

14. The rotary magnetic encoder assembly of claim 13 wherein the magnet retainer comprises a pocket formed in the encoder body in which the rotatable magnet is received.

15. The rotary magnetic encoder assembly of claim 11 further comprising at least one of an encoder body and encoder housing and wherein the magnet retainer is carried by one of the encoder body and encoder housing.

16. The rotary magnetic encoder assembly of claim 10 wherein the magnetic field sensor arrangement comprises an integrated circuit and the magnet retainer comprises a module that is mountable to the integrated circuit.

17. The rotary magnetic encoder assembly of claim 16 wherein the magnetic field sensor arrangement comprises at least a plurality of pairs of Hall sensors disposed onboard the integrated circuit.

18. The rotary magnetic encoder assembly of claim 16 wherein the magnet retainer comprises a pocket formed in the module and the rotatable magnet is received in the pocket.

19. The rotary magnetic encoder assembly of claim 10 wherein the magnetic field sensor arrangement comprises an integrated circuit having a package body and the magnet retainer comprises a pocket disposed therein in which the rotatable magnet is rotatively received.

20. The rotary magnetic encoder assembly of claim 19 wherein the magnetic field sensor arrangement comprises a plurality of Hall sensors disposed onboard the integrated circuit arranged in a sensor array that defines a sensor region that underlies the magnet-holding pocket and the rotatable magnet disposed in the magnet-holding pocket.

21. The rotary magnetic encoder assembly of claim 19 wherein the pocket is integrally formed in the package body during manufacture of the integrated circuit.

22. A rotary magnetic encoder assembly comprising:

- (a) an encoder body or encoder housing;
- (b) a rotary magnetic encoder integrated circuit carried by the encoder body or encoder housing, the rotary magnetic encoder integrated circuit comprised of a plurality of Hall sensors that define a magnetic field sensor region;
- (c) a magnet retainer carried by the encoder body or encoder housing that is disposed adjacent the magnetic field sensor region of the rotary magnetic encoder integrated circuit;
- (d) a rotatable magnet carried by the magnet retainer;
- (e) a rotary encoder shaft that effects rotation of the rotatable magnet without contacting the rotatable magnet; and

wherein the magnet retainer locates the rotatable magnet relative to the magnetic field sensor region of the rotary magnetic encoder integrated circuit.

23. The rotary magnetic encoder assembly of claim 22 wherein the magnet retainer comprises a pocket formed in the encoder body in which the rotatable magnet is rotatively disposed and wherein the rotary encoder shaft further comprises a drive magnet disposed at or adjacent its free end that magnetically couples the rotatable magnet such that the rotatable magnet rotates substantially in unison with the drive magnet and encoder shaft.

24. The rotary magnetic encoder assembly of claim 22 wherein the magnet retainer comprises a pocket formed in an insert that engages the encoder body with the rotatable magnet disposed in the pocket.

25. The rotary magnetic encoder assembly of claim 22 wherein the magnet retainer comprises a pocket that accurately locates the rotatable magnet axially and radially relative to magnetic field sensor region of the rotary magnetic encoder integrated circuit.

25. The rotary magnetic encoder assembly of claim 25 wherein the pocket overlies or is disposed in line with the magnetic field sensor region of the rotary magnetic encoder integrated circuit.

26. The rotary magnetic encoder assembly of claim 26 wherein the encoder shaft further comprises a permanent magnet that magnetically couples with the rotatable magnet for rotating the rotatable magnet substantially in unison with the encoder shaft.

27. A rotary magnetic encoder assembly comprising:

- (a) an encoder body or encoder housing;
- (b) a rotary magnetic encoder integrated circuit disposed onboard, the rotary magnetic encoder integrated circuit comprised of a plurality of Hall sensors that define a magnetic field sensor region;
- (c) a freewheeling rotatable magnet disposed onboard that emits a magnetic field detectable by at least one of the Hall sensors when the rotatable magnet rotates; and
- (d) an encoder shaft having a drive magnet that magnetically couples with the freewheeling rotatable magnet during encoder shaft rotation.

28. The rotary magnetic encoder assembly of claim 27 wherein the encoder shaft rotates relative to the encoder housing or encoder body without being rotatively supported thereby.

29. A rotary magnetic encoder integrated circuit for a rotary magnetic encoder assembly comprising:

- (a) an integrated circuit package body from which outwardly extends a plurality of electrically conductive pins;
- (b) a magnetic field sensor arrangement disposed in the package body; and
- (c) a rotatable magnet disposed in a pocket that overlies the magnetic field sensor arrangement.

30. The rotary magnetic encoder integrated circuit of claim 29 wherein rotatable magnet holding pocket is integrally formed in the package body.

31. The rotary magnetic encoder integrated circuit of claim 29 wherein the magnet-holding pocket is disposed in a module that is attachable to the package body.

32. The rotary magnetic encoder integrated circuit of claim 29 wherein magnetic field sensor arrangement comprises a plurality of pairs of Hall sensors and wherein the magnet holding pocket accurately radially and axially locates the rotatable magnet relative thereto.

\* \* \* \* \*