

INTERFACE DETAILS AND NOTES:

1. APPLICATION SHAFT Ø.375" MINIMUM WHEN USING MAG-H APPLICATION MAGNET. TAP 1/4-20 A MINIMUM DEPTH OF .375".
2. 0.25" SENSOR GAP DISTANCE IS OPTIMAL FOR NORMAL INSTALLATION. THIS IS DEPENDNT ON MOUNT AND MATERIALS.

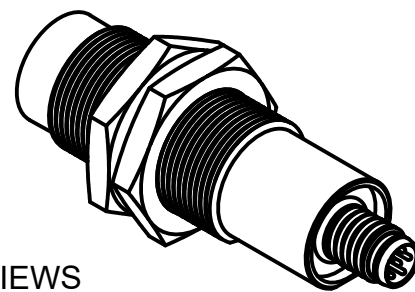
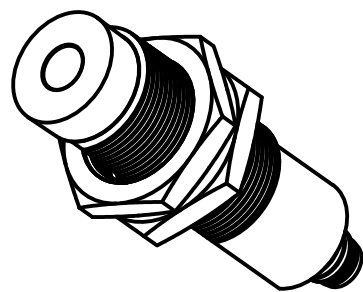
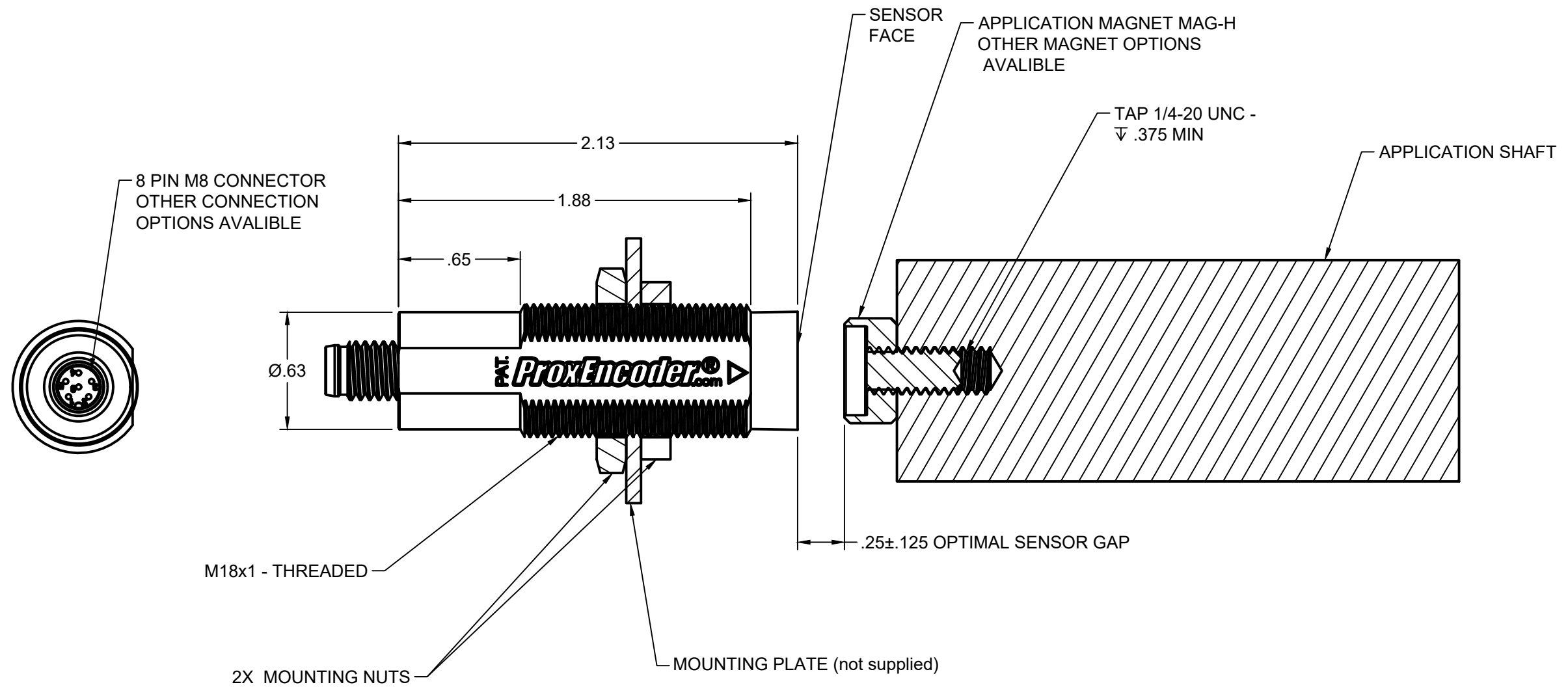

ISOMETRIC VIEWS
SCALE:NONE

CONFIDENTIAL - ALL RIGHTS RESERVED
DISCLOSURE OR DUPLICATION PROHIBITED

UNLESS OTHERWISE SPECIFIED:
DIMENSIONS ARE IN DECIMAL INCH

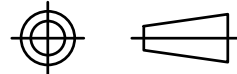

ALL DIMENSIONS ARE REFERENCE

DRAWN:
Tyler Wolff

DATE:
6/28/2024

CHECKED:
A. MINSTER

APPROVED:
7/01/2024

PART #:
PE18 CUSTOMER ASSY

EPICOR #:
REV. SIZE:
B

JORAL
WWW.JORALLC.COM

DESCRIPTION:
18MM PROX ENCODER

SCALE:
3:2
SHEET:
1/1