

KEEPOUT AREA -CONNECTOR LOCATION IS A REFERENCE. CONTACT FACTORY FOR EXACT LOCATION

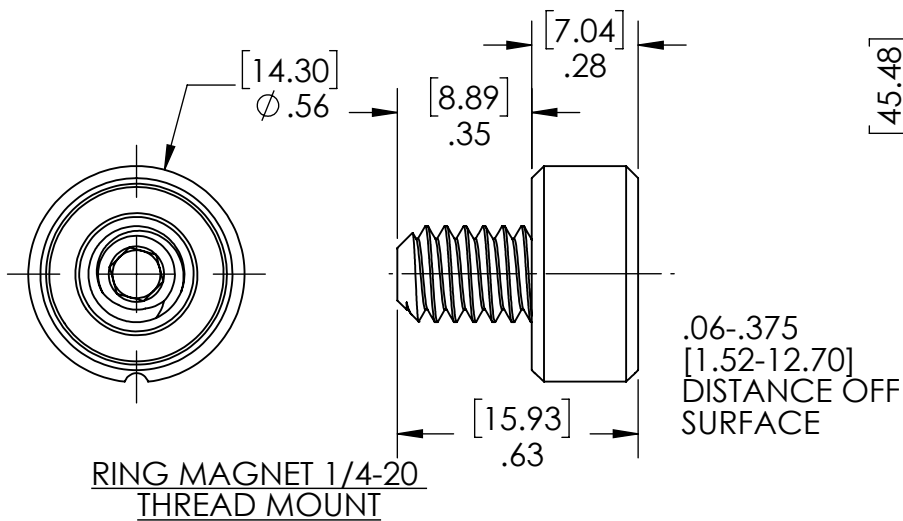
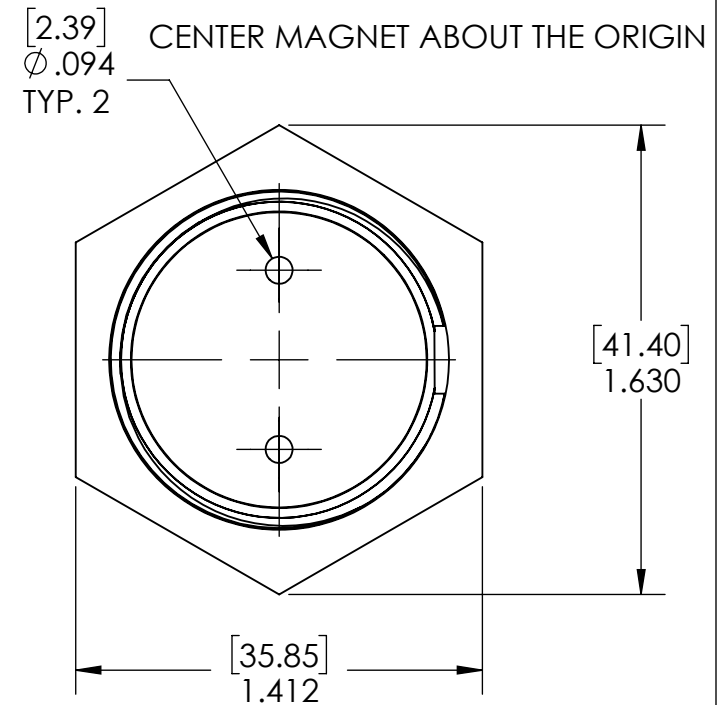
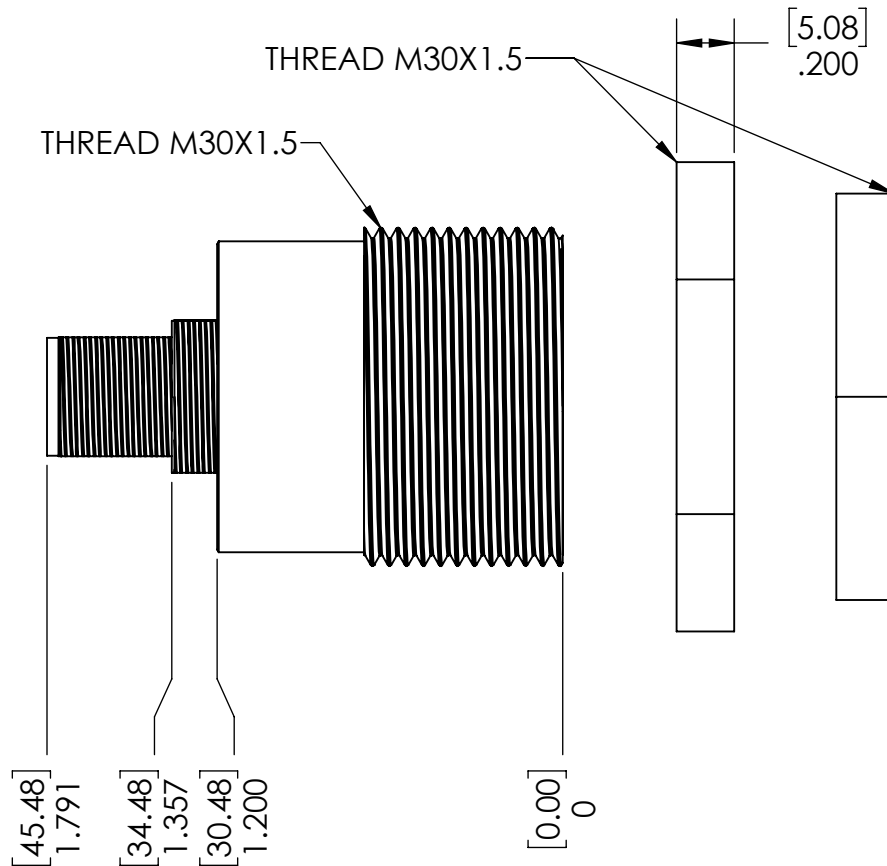

MATERIAL:
 PLASTIC IS ACETAL
 CONNECTOR IS NICKEL PLATED BRASS
 ENCODED IS FILLED WITH EPOXY

CONFIDENTIAL-ALL RIGHTS RESERVED
 DISCLOSURE OR DUPLICATION PROHIBITED

UNLESS OTHERWISE SPECIFIED:
 DIMENSIONS ARE DECIMAL INCH

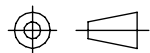

MANUFACTURING TOLERANCES
 .X .XX .XXX ANGLE
 ±.015 ±.005 ±.001 1°

DESIGN: JOE	DATE: 08-24-20	DRAFTING:	DATE:
CHECKED: GOV	DATE: 08-24-20	APPROVED:	DATE:
B.O.M.		RELEASED:	DATE:
CUSTOMER:		SIZE AL	SCALE 3:2



WWW.JORALLLC.COM

TITLE: LP30-M12-33	DWG NO. : C48001	REV. 0	SHEET: 1 OF 1
-----------------------	---------------------	-----------	------------------

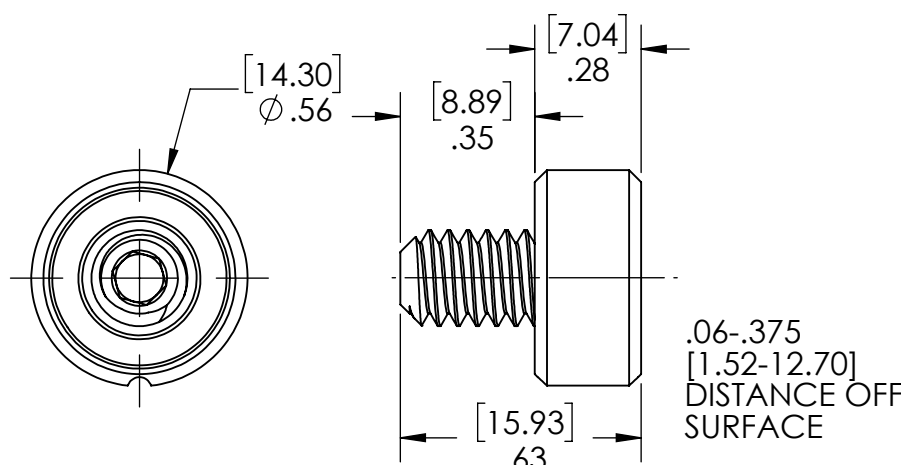
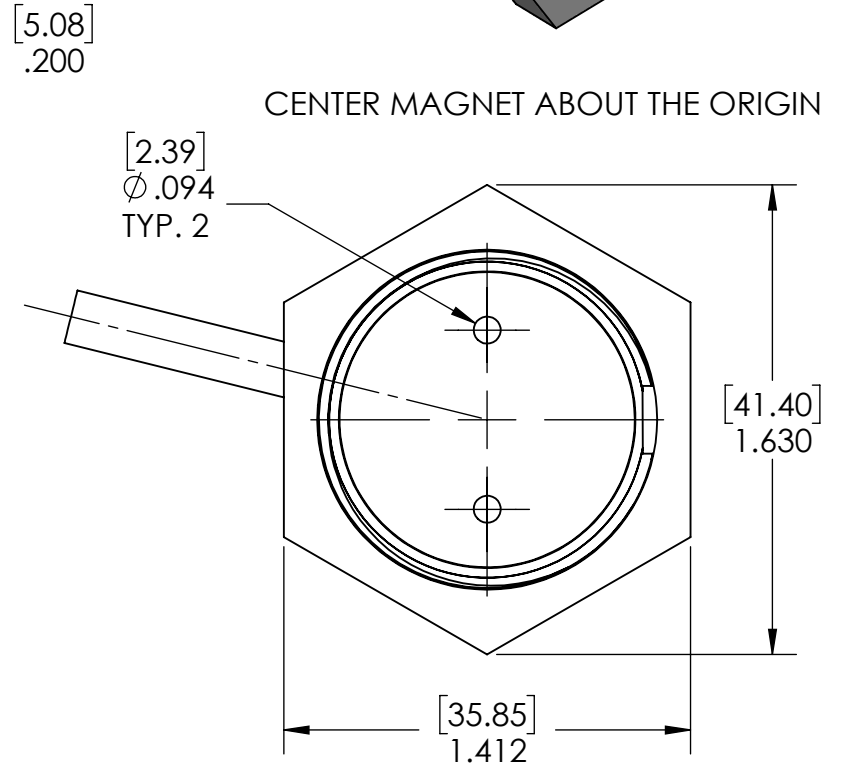
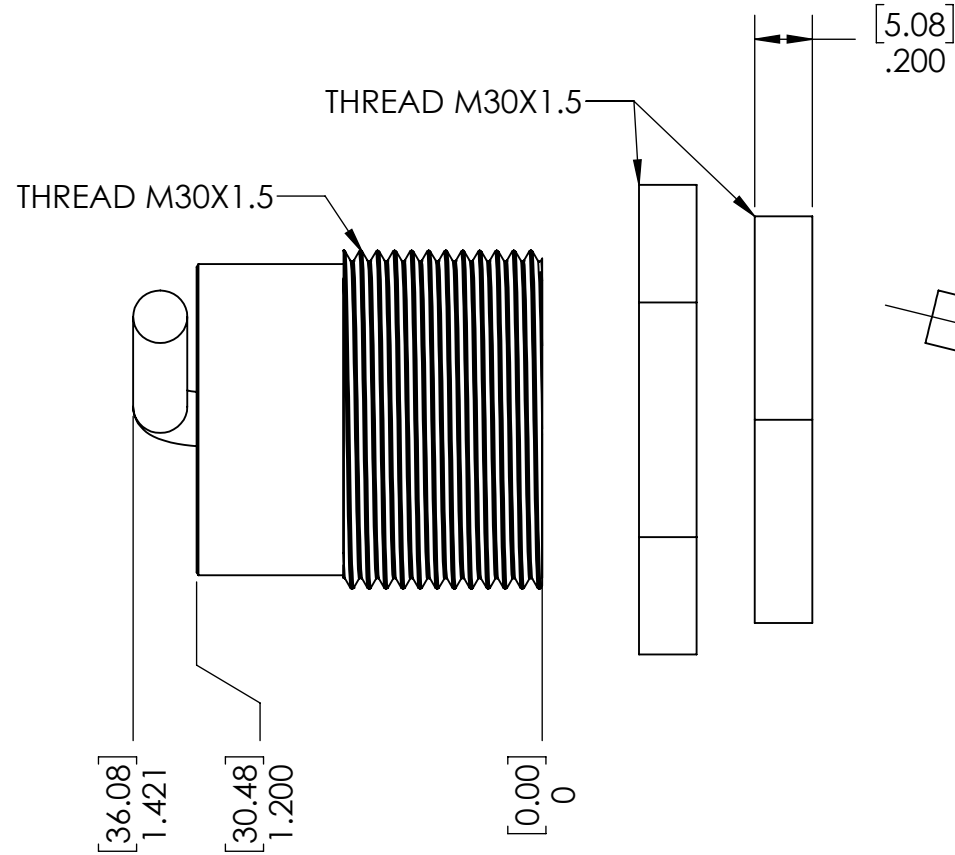
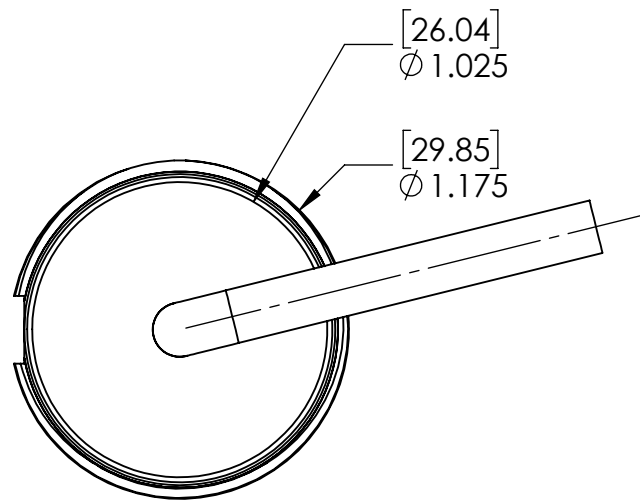
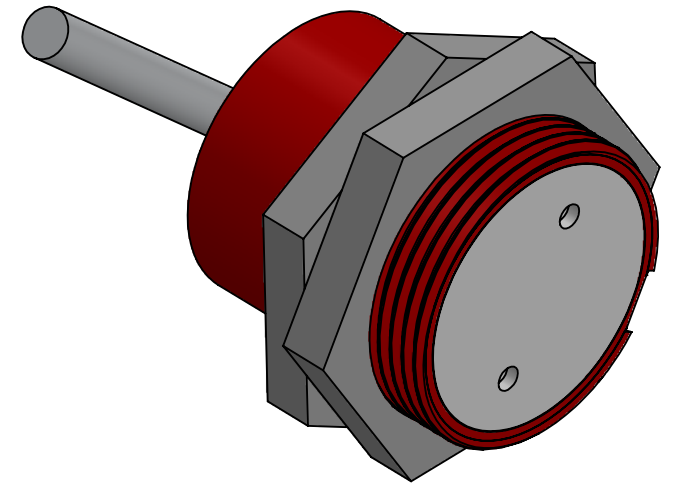
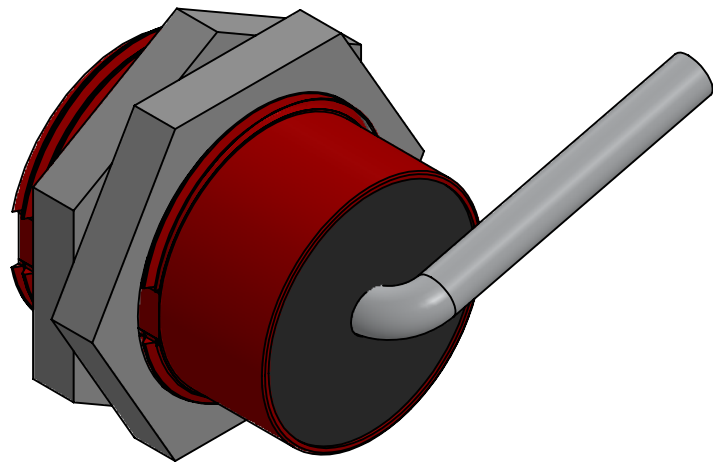

RING MAGNET 1/4-20
THREAD MOUNT

MATERIAL:
PLASTIC IS ACETAL
ENCODER IS FILLED WITH EPOXY
ENCODER IS ALUMINIUM

CONFIDENTIAL-ALL RIGHTS RESERVED
DISCLOSURE OR DUPLICATION PROHIBITED
UNLESS OTHERWISE SPECIFIED:
DIMENSIONS ARE DECIMAL INCH
MANUFACTURING TOLERANCES
.X ±.015 | .XX ±.005 | .XXX ±.001 | ANGLE 1°

DESIGN: JOE	DATE: 08-24-20	DRAFTING:	DATE:
CHECKED: GOV	DATE: 08-24-20	APPROVED:	DATE:
B.O.M.		RELEASED:	DATE:
CUSTOMER:		SIZE AL	SCALE 3:2

JORAL		WWW.JORALLLC.COM	
		TITLE: LP30-CBL-33	
DWG NO.:	REV.	SHEET:	
C48002	0	1 OF 1	