



SINC 3-AXIS INCLINOMETER, SINGLE MODULE

- Easy mounting, sense true position regardless of orientation
 - 3-axis sensing (X, Y, and Z)
- Totally sealed IP69K (connector dependent)
- Wide operating temperature range, -40°C to +85°C
- J1939 CAN Bus or varying voltage output
- 'Electronic Bubble' LEDs display level status
- Configuration available through J1939 for sensitivity and angular range settings

ELECTRICAL	Outputs	B-1939 : J1939, Addressable, 3-axis reporting B-ANLG : Contact Joral to build custom analog signal
	Input Power	6 to 30 VDC (90 mA)
	Electrical Protection	Over-voltage, reverse-voltage, output short-circuit protected
	LED Indicators	Power, J1939 communication status, level status, and X/Y level condition
	Connections	M12, M12 Pigtail, Flying Lead Cable, Shielded Flying Lead, or Deutsch - 4 or 6 pin
	Resolution	0.1°
	Absolute Accuracy (at 25°C)	± 0.3°

MECHANICAL	Housing Style	Rectangular tabbed
	Housing Material	Plastic or Anodized Aluminum (high temperature applications)
	Housing Height	Plastic - 1.0"; Aluminum - Contact Joral
	Housing Width	Plastic - 1.5"; Aluminum - Contact Joral
	Housing Length w/ Tabs	Plastic - 3.0"; Aluminum - Contact Joral
	Mounting	Tabs (0.187 diameter holes)
	Weight	3.0 oz

ENVIRONMENTAL	Operating Temperature	-40° to +80° C
	Temperature Drift	±0.3 degrees across specified operating temperature limits
	Storage Temperature	-40° to +90° C
	Humidity	100%
	Shock	400g/6ms (<i>MIL STD 202</i>)
	Vibration	5 to 3000 Hz, 20g (<i>MIL STD 202</i>)
Protection Class	IP69K (<i>connection dependent</i>)	

		Code 1: Housing Style	Code 2: MagElec	Code 3: Connection	Code 4: Modifiers		
ORDER TABLE	SINC Black plastic housing standard, not rated for high temp applications	B-1939	J1939, Addressable, 3-axis position reporting	M12	M12 male	51 Red Aluminum	
		B-ANLG	Contact Joral to build custom analog signal	M12P	M12 male on 18' pigtail	53 Black Aluminum	
	SINC Modifier Red Aluminum: SINC-[Code 2]-[Code 3]-51 Special code 51 (53) for anodized red (black) aluminum high temp housing			CXX	Flying lead cable (enter XX as inches)		
				SCXX	Shielded cable (enter XX as inches)		
				DE4	DT04-4 pin male Deutsch		
				DE6	DT04-6 pin male Deutsch		
*More outputs and connection options available, contact Joral if desired configuration is not listed							

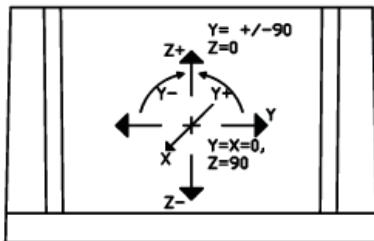
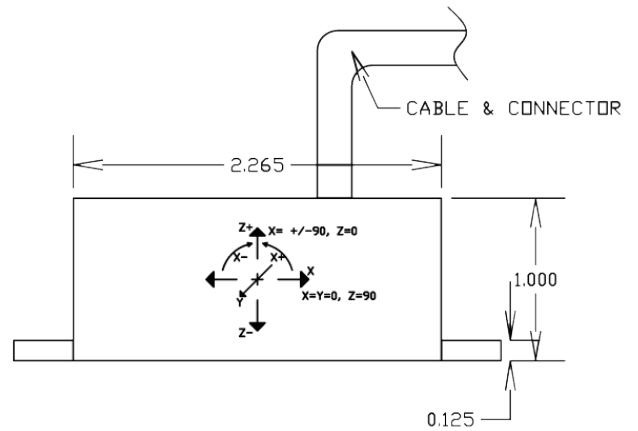
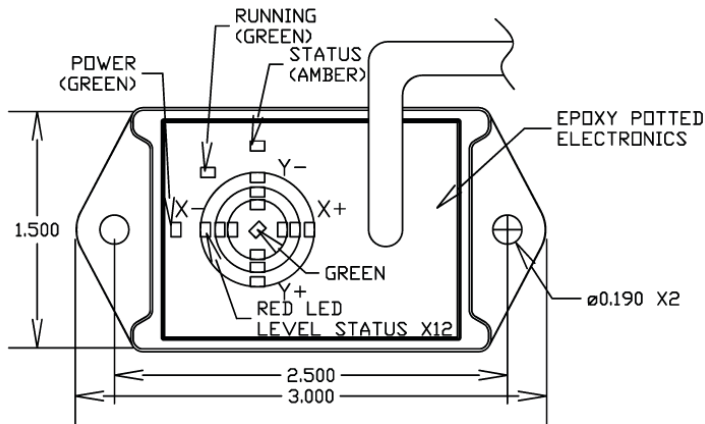

GENERAL PIN OUTS

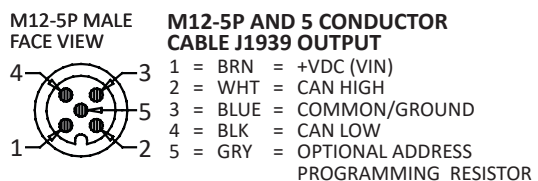
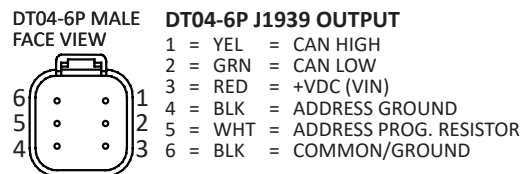
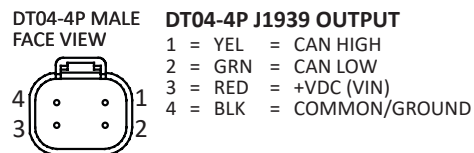

Dimensions informative only
For most recent dimensions please consult factory

MESSAGE PARAMETERS

This message is transmitted to the sensor at the REP rate

PGN: 65281 (FF01 hex)	
Transmission Repetition Rate	n/a
Data Length	n/a
Data Page	0
PDU Format	255 (FF hex)
PDU Specific	1 (01 hex)
Priority	7
Source Address+Adr Offset	249 (F9 hex)
Communication Bit Rate	250 K bits/sec

Field	Size/Bits	Description
Sensitivity Setting	3 bits / 0 to 2	0 = most sensitive, 7 = most sluggish (default 4)
LED Weight Setting	3 bits / 5 to 7	The desired degrees per LED indicator is entered in this field. The desired degrees per LED indicator has to be between 1 to 7 (default 1)
Calibrate/Home Field	2 bits / 8 to 9	01 = Calibrate/Home the sensor at the current angles

Note: Set reserved and unused bits to all 0's or all 1's

Encoder Transmitted Source Address Selection			
Tag #	Ohms	Address	PGN
	No resistor	NA	65281 FF01 hex
1	590	NA	65282 FF02 hex
2	976	NA	65283 FF03 hex
3	1500	NA	65284 FF04 hex
4	2260	NA	65285 FF05 hex
5	3400	NA	65286 FF06 hex
6	5360	NA	65287 FF07 hex
7	9530	NA	65288 FF08 hex

DT04-4P MALE FACE VIEW



DT04-4P J1939 OUTPUT

- 1 = YEL = CAN HIGH
- 2 = GRN = CAN LOW
- 3 = RED = +VDC (VIN)
- 4 = BLK = COMMON/GROUND

M12-5P MALE FACE VIEW

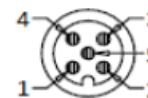

DT04-6P MALE FACE VIEW



DT04-6P J1939 OUTPUT

- 1 = YEL = CAN HIGH
- 2 = GRN = CAN LOW
- 3 = RED = +VDC (VIN)
- 4 = BLK = ADDRESS GROUND
- 5 = WHT = ADDRESS PROG. RESISTOR
- 6 = BLK = COMMON/GROUND

M12-5P AND 5 CONDUCTOR CABLE J1939 OUTPUT

- 1 = BRN = +VDC (VIN)
- 2 = WHT = CAN HIGH
- 3 = BLUE = COMMON/GROUND
- 4 = BLK = CAN LOW
- 5 = GRY = OPTIONAL ADDRESS PROGRAMMING RESISTOR

Arbitration Field																								Control Field																
0	1	2	3	4	5	6	7	8	9	10	11	12	13	14	15	16	17	18	19	20	21	22	23	24	25	26	27	28	29	30	31	32	33	34	35	36	37	38		
SOF	Priority 3 Bits			R1	DP	PDU Format (PF) 8 bits						SRS	IDE	PF Cont.		PDU Specific 8 bits						Source Address 8 bits						RTR	Control Field 6 bits											
X	0	1	2	0	0	0	1	2	3	4	5	X	X	6	7	0	1	2	3	4	5	6	7	0	1	2	3	4	5	6	7	X	0	1	2	3	5	6		
	1	0	0	0		1	1	1	1	1	1			1	1	1	0	1	1	1	0	0	1	1	1	0	1	1	1	0	0									
	7				255 (FF hex)								1 (01 hex)		249 (F9 hex)																									
	65281 + Address Offset																							249 Mandatory																

MESSAGE PARAMETERS

This message is transmitted by the sensor at the REP rate

PGN: 65465 (FFB9 hex)	
Transmission Repetition Rate	50ms
Data Length	8 bytes
Data Page	0
PDU Format	255 (FF hex)
PDU Specific	185 (B9)
Priority	4
Source Address+Adr Offset	220 (DC hex)
Communication Bit Rate	250 K bits/sec

Encoder Transmitted Source Address Selection			
Tag #	Ohms	Address	PGN
	No resistor	220	65465 FFB9 hex
1	590	221	65465 FFB9 hex
2	976	222	65465 FFB9 hex
3	1500	223	65465 FFB9 hex
4	2260	224	65465 FFB9 hex
5	3400	225	65465 FFB9 hex
6	5360	226	65465 FFB9 hex
7	9530	227	65465 FFB9 hex

Field	Size/Bits	Description
X Angle	10 bits / 0 to 9	The X angle is a value between 0-1000 and there is 0.1° per bit
X Positive Flag	2 bits / 10 to 11	01 = X angle is a positive angle
X Negative Flag	2 bits / 12 to 13	01 = X angle is a negative angle
Y Angle	10 bits / 14 to 23	The Y angle is a value between 0-1000 and there is 0.1° per bit
Y Positive Flag	2 bits / 24 to 25	01 = Y angle is a positive angle
Y Negative Flag	2 bits / 26 to 27	01 = Y angle is a negative angle
Z Angle	10 bits / 28 to 37	The Z angle is a value between 0-1000 and there is 0.1° per bit
Z Positive Flag	2 bits / 38 to 39	01 = Z angle is a positive angle
Z Negative Flag	2 bits / 40 to 41	01 = Z angle is a negative angle
Sensitivity Setting	3 bits / 56 to 58	The sensitivity setting field contains the value of the current sensitivity setting. The setting is between 1 to 7 and this represents the degrees per LED indicator.
LED Weight Setting	3 bits / 59 to 61	The LED weight setting field contains the value of the current LED weight setting. The setting is between 1 to 7 and this represents the degrees per LED indicator.

DT04-4P MALE FACE VIEW



DT04-4P J1939 OUTPUT

- 1 = YEL = CAN HIGH
- 2 = GRN = CAN LOW
- 3 = RED = +VDC (VIN)
- 4 = BLK = COMMON/GROUND

M12-5P MALE FACE VIEW

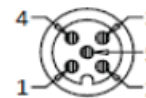

DT04-6P MALE FACE VIEW



DT04-6P J1939 OUTPUT

- 1 = YEL = CAN HIGH
- 2 = GRN = CAN LOW
- 3 = RED = +VDC (VIN)
- 4 = BLK = ADDRESS GROUND
- 5 = WHT = ADDRESS PROG. RESISTOR
- 6 = BLK = COMMON/GROUND

M12-5P AND 5 CONDUCTOR CABLE J1939 OUTPUT

- 1 = BRN = +VDC (VIN)
- 2 = WHT = CAN HIGH
- 3 = BLUE = COMMON/GROUND
- 4 = BLK = CAN LOW
- 5 = GRY = OPTIONAL ADDRESS PROGRAMMING RESISTOR

Arbitration Field																															Control Field																	
0	1	2	3	4	5	6	7	8	9	10	11	12	13	14	15	16	17	18	19	20	21	22	23	24	25	26	27	28	29	30	31	32	33	34	35	36	37	38										
SOF	Priority 3 Bits			R1	DP	PDU Format (PF) 8 bits						SRS	IDE	PF Cont.		PDU Specific 8 bits								Source Address 8 bits							RTR	Control Field 6 bits																
X	0	1	2	0	0	0	1	2	3	4	5	X	X	6	7	0	1	2	3	4	5	6	7	0	1	2	3	4	5	6	7	X	0	1	2	3	5	6										
	1	0	0		0		1	1	1	1	1			1	1	1	0	1	1	1	0	0	1	1	1	0	1	1	1	0	0																	
	4					255 (FF hex)								185 (B9 hex)								220 (DC hex)																										
	65465															220 + Address Offset																																

	bit7	bit6	bit5	bit4	bit3	bit2	bit1	bit0	
Data Field	X Angle								
	X Angle							LSB	
	LSB		X NEG flag		X POS flag		MSB		
	Y Angle								
	MSB				Y Angle				
	Z Angle				LSB		Y NEG flag		Y POS flag
	Z POS flag		MSB						
	1	1	1	1	1	1	1	Z NEG flag	
1	1	1	1	1	1	1	1		
0	0	LED Weight				Sensitivity			

64 BIT DATA FIELD BIT POSITIONS

X Angle (10 bits) 0 to 1000, 0.1 per bit
X angle POSITIVE sign flag (2 bits) 01 = Positive Angle
X angle NEGATIVE sign flag (2 bits) 01 = Negative Angle
Y Angle (10 bits) 0 to 1000, 0.1 per bit
Y angle POSITIVE sign flag (2 bits) 01 = Positive Angle
Y angle NEGATIVE sign flag (2 bits) 01 = Negative Angle
Z Angle (10 bits) 0 to 1000, 0.1 per bit
Z angle POSITIVE sign flag (2 bits) 01 = Positive Angle
Z angle NEGATIVE sign flag (2 bits) 01 = Negative Angle

SENSITIVITY Setting (3 bits) Field contains the value of the current setting. 0 = most sensitive, 7 = most sluggish (default 4)
LED WEIGHT Setting (3 bits) Field contains the value of the setting. Degrees per LED Indicator, 1 to 7 (default 1)

Byte 0								Byte 1								Byte 2								Byte 3							
0	1	2	3	4	5	6	7	8	9	10	11	12	13	14	15	16	17	18	19	20	21	22	23	24	25	26	27	28	29	30	31
X Angle bit0 LSB	X Angle bit1	X Angle bit2	X Angle bit3	X Angle bit4	X Angle bit5	X Angle bit6	X Angle bit7	X Angle bit8	X Angle bit9 MSB	X Positive Flag LSB	X Positive Flag MSB	X Negative Flag LSB	X Negative Flag MSB	Y Angle bit0 LSB	Y Angle bit1	Y Angle bit2	Y Angle bit3	Y Angle bit4	Y Angle bit5	Y Angle bit6	Y Angle bit7	Y Angle bit8	Y Angle bit9 MSB	Y Positive Flag LSB	Y Positive Flag MSB	Y Negative Flag LSB	Y Negative Flag MSB	Z Angle bit0 LSB	Z Angle bit1	Z Angle bit2	Z Angle bit3

Byte 4								Byte 5								Byte 6								Byte 7							
32	33	34	35	36	37	38	39	40	41	42	43	44	45	46	47	48	49	50	51	52	53	54	55	56	57	58	59	60	61	62	63
Z Angle bit4	Z Angle bit5	Z Angle bit6	Z Angle bit7	Z Angle bit8	Z Angle bit9	Z Positive Flag LSB	Z Positive Flag MSB	Z Negative Flag LSB	Z Negative Flag MSB	UNUSED	UNUSED	UNUSED	UNUSED	UNUSED	UNUSED	UNUSED	UNUSED	UNUSED	UNUSED	UNUSED	UNUSED	UNUSED	UNUSED	Sensitivity bit0 LSB	Sensitivity bit1	Sensitivity bit2 MSB	LED Weight bit0 LSB	LED Weight bit1	LED Weight bit2 MSB	UNUSED	UNUSED